

FORM 3 2023 MIDTERM 1 EXAM

232/2
PHYSICS
FORM THREE
PAPER 2
TIME: 2 HOURS

INSTRUCTIONS TO CANDIDATES

1. Write your name and index number in the spaces provided at the top of this page.
2. Sign and write the date of examination in the spaces provided above.
3. This paper consists of TWO sections: A and B
4. Answer ALL the questions in the sections A and B in the spaces provided.
5. ALL working MUST be clearly shown.
6. Non-programmable silent electronic calculators and KNEC mathematical tables may be used.

FOR EXAMINERS USE ONLY.

SECTION	QUESTIONS	MAXIMUM SCORE	CANDIDATE'S SCORE
A	1 – 13	25	
B	14	12	
	15	11	
	16	12	
	17	08	
	19	11	
Total Score		80	

This paper consists of 12 printed pages.

Candidates should check the question paper to ensure that all pages are printed as indicated and that no questions are missing.

Section A (25 marks)

1. Give one difference between luminous and non-luminous sources of light. (1mk)

.....
.....
.....

2. When a negatively charged rod is brought near the cap of a leaf electroscope, the leaf rises. Explain this observation, (2mks)

.....
.....
.....

3. **Figure 2** represents a displacement-time graph for a wave.

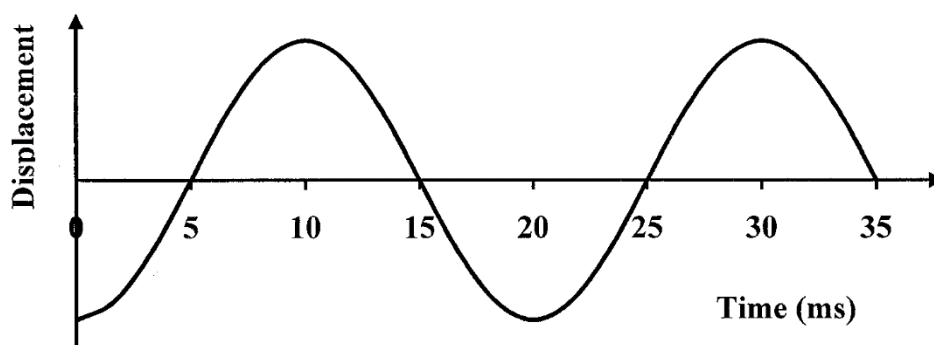

Figure 2

- Determine the frequency of the wave. (2mks)

.....
.....
.....

4. **State** the conditions necessary for a wave incident on a slit to be diffracted. (2mrks)

.....
.....
.....
.....

5. In an experiment to determine the focal length of a concave mirror, magnification M was determined for various image distances v . Figure 3 shows a graph of magnification M against image distance v for the results from the experiment.

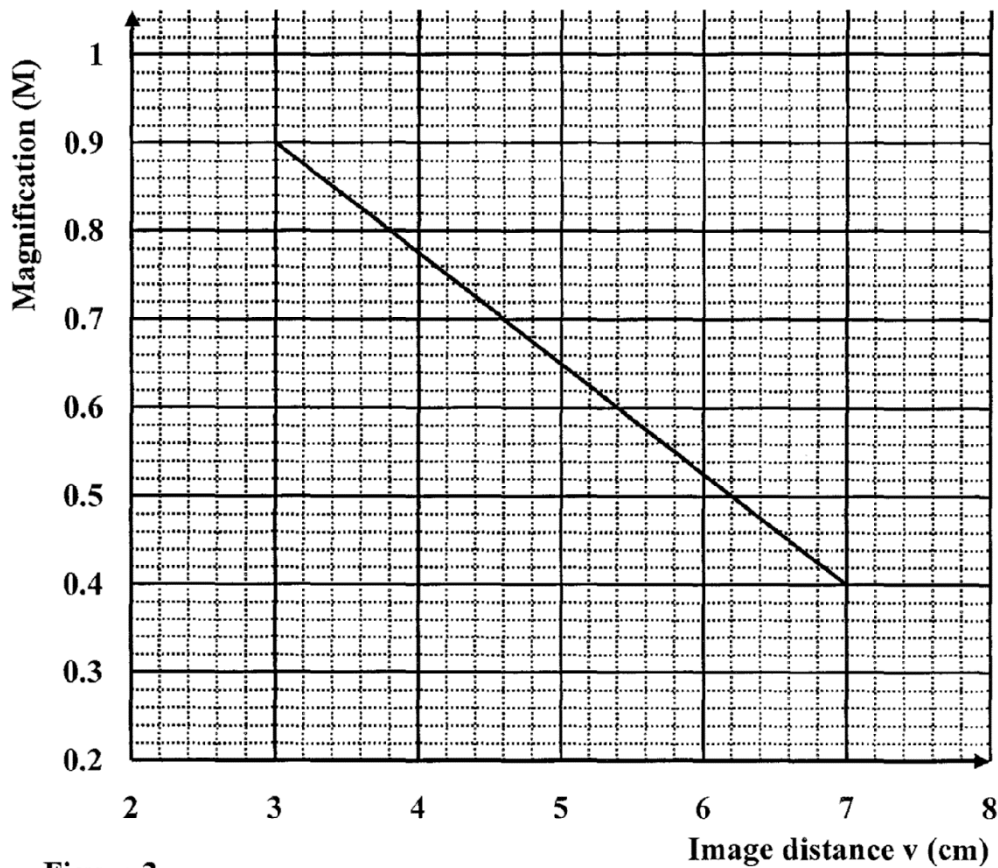

Figure 3

Given that $M = 1 \frac{v}{f}$, determine the focal length f of the mirror. (3mks)

.....
.....
.....
.....

6. A hair dryer is rated 2500W, 240V. Determine its resistance. (2mks)

.....
.....

7. **Figure 4** shows the magnetic field pattern round a current-carrying conductor. Indicate on the conductor the direction of the current. (1mk)

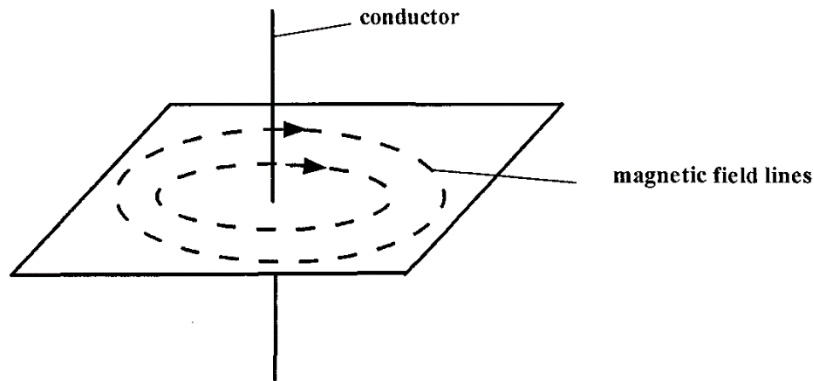

Figure 4

8. Why is repulsion the sure test for a magnet? (1mk)

.....
.....

9. **Figure 5** shows a ray of light incident on an air bubble which is inside water,

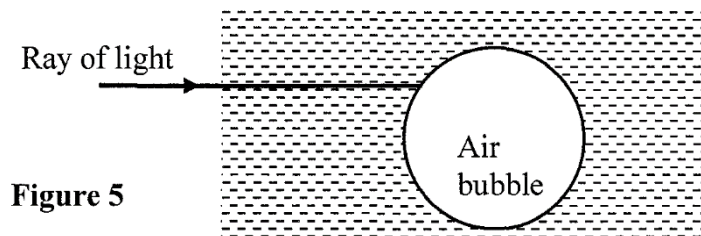

Figure 5

Complete the ray to show the path it follows through the air bubble. (1mk)

10. Explain how polarization of a cell increases the cell's internal resistance. (2mks)

.....
.....
.....
.....

11.

1. A positively charged material was brought close to an insulated metallic ball as shown in Fig 4. State and explain the distribution of charge in the ball (2mks)

Fig. 4

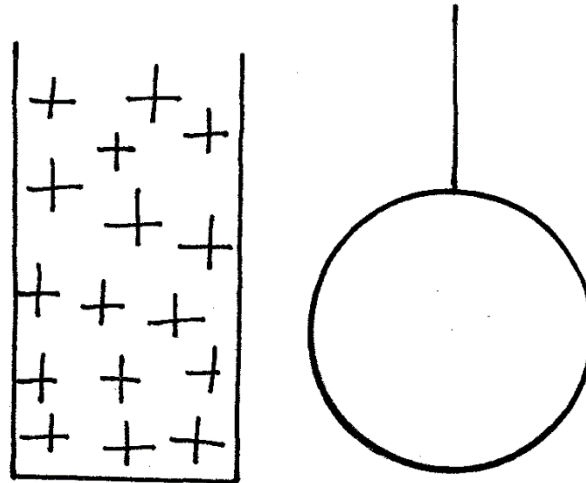

.....

.....

.....

.....

2. Explain why sound cannot be heard from far when one shouts in a forest (1mk)

.....

.....

12. Using the variation of resistance with temperature, differentiate between a conductor and a semiconductor. (1mk)

.....

.....

.....

13. A cell of internal resistance $0.5\ \Omega$ is in a circuit containing a $10\ \Omega$ resistor. A current of 2A flows in the circuit. Determine the emf of the cell. (2mks)

.....

.....

.....
.....

Section B (55 marks)

14. (a) (i) State Snell's law of refraction of light (1mk)

.....
.....

(ii) Give two advantages of totally internally reflecting prisms over plane mirrors. (2mks)

.....
.....

(b) A ray of light is incident on a kerosene water interfaces as shown in figure 7

Fig. 7

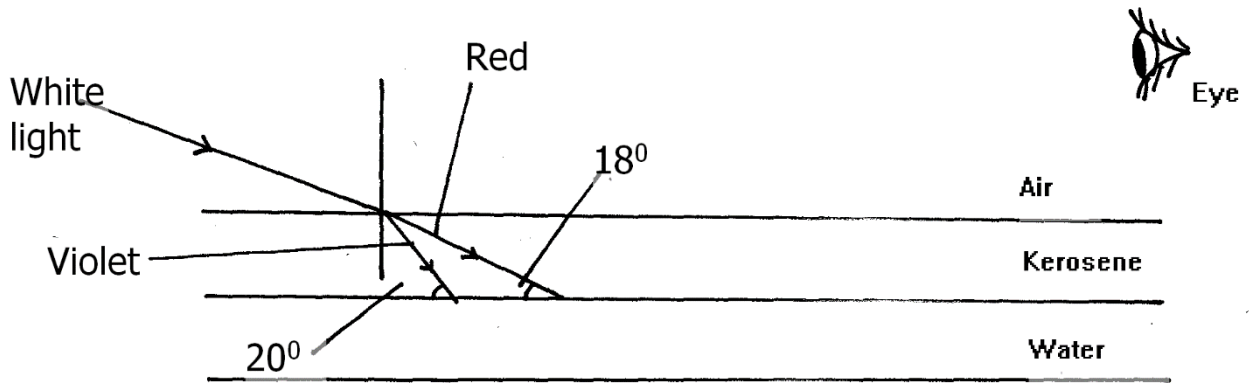

Given that the refractive index of water and kerosene are 1.33 and 1.44 respectively,

Determine

(i) the refractive index for the kerosene – water interface (3mks)

.....

.....

.....

.....

.....

.....

(ii) determine and show on the figure the path of the rays of light between the Kerosene-water surface (3mks)

.....

.....

.....

.....

.....

.....

(iii) Why does the colours of the light separate at the kerosene layer. (1mk)

.....

.....

(iv) State and explain the observation that the eye above the two surfaces would see (2mks)

.....

.....

.....

.....

15. (a) State Ohm's law (1mk)

.....
.....

(b) The figure 8 below shows a circuit with a coil used to warm oil in a beaker.

Fig. 8

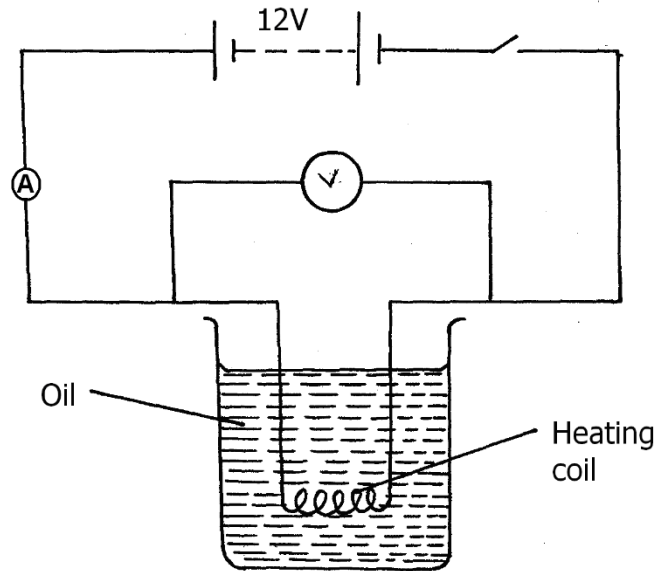

(i) Explain how heat is produced in the coil (2mks)

.....
.....
.....

(ii) Given that the reading of the ammeter is 2.4A determine the resistance of the coil. (3mks)

.....
.....
.....

(iii) How much heat is produced in the coil in a minute? (3mks)

.....
.....
.....
.....

(iv) Give two changes that can be made in the set up in order to produce more heat per minute. (2mks)

.....
.....
.....

16. (a) Define capacitance of a capacitor (1mk)

.....
.....

The figure below shows a charged electroscope two aluminium plates A and B arranged as shown

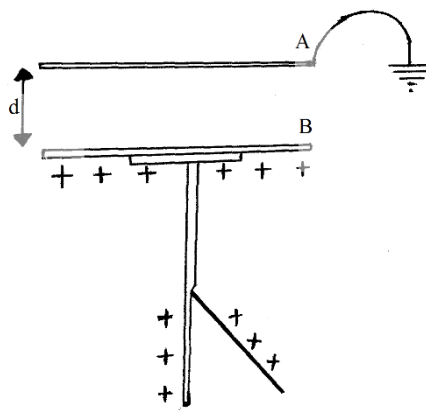

State and explain the observations made when:

(i) d is reduced (2mks)

.....
.....

(ii) the plate A is more horizontally (2mks)

.....
.....

(iii) a sheet of polythene is placed between A and B (2mks)

.....
.....

(b) Three capacitors are connected to a 10V battery as shown below.

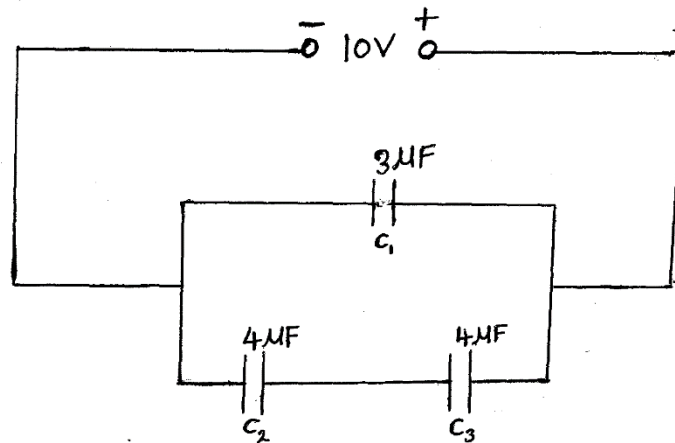

(i) Calculate the combined capacitance (3mks)

(ii) What is the charge on the $3\mu\text{F}$ capacitor (3mks)

17. Students set up a mass attached to spring such that when it oscillates it taps on water surface in a wide shallow tank.

Fig. 6

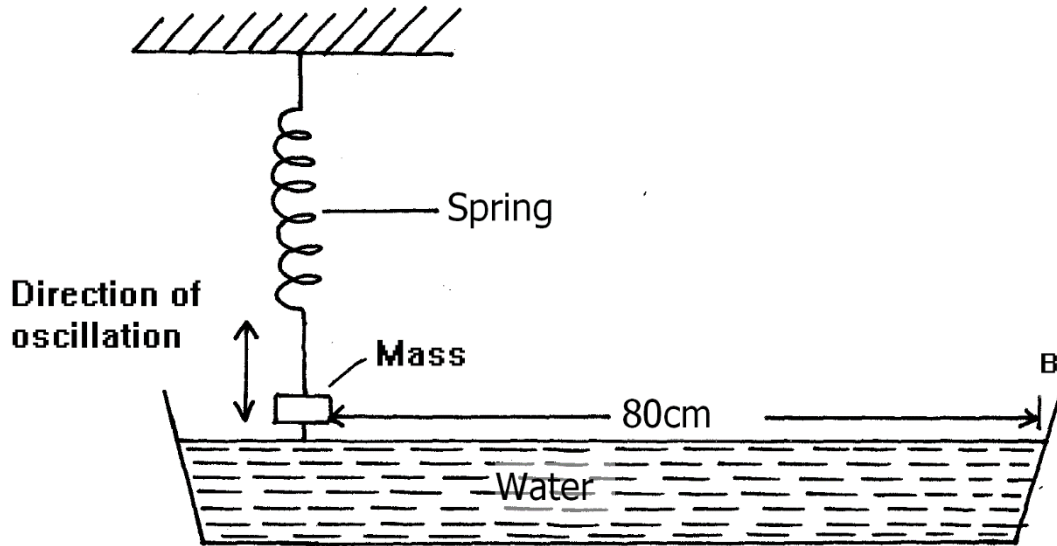

The students measured time for 20 oscillations and found that the mass takes 36 seconds.

- (i) Determine the periodic time of the mass (2mks)

.....
.....

- (ii) Calculate the frequency of the waves produced on the water surface (3mks)

.....
.....
.....

- (iii) Given that the student counted four ripples between the mass and end B of the tank, Determine the speed of the waves. (3mks)

.....
.....
.....
.....
.....

18.

- a. A machine is a device that enables work to be done more easily and conveniently. State any two ways in which a machine makes work easier. (2 marks)

.....

.....

.....

.....

.....

- b. Figure 7 shows a wheel and axle being used to raise a load W by applying an effort E. The radius of the wheel is R and of the axle is r.

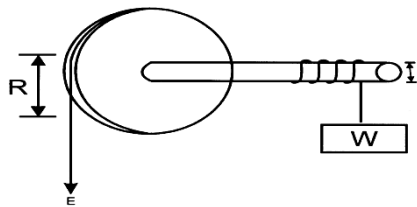

- i) Show that the velocity ratio (V.R) of this machine is given by $\frac{R}{r}$ (3 Marks)

.....

.....

.....

.....

.....

- ii) Given that $r = 5\text{cm}$ and $R = 50\text{cm}$, determine the effort required to raise a load of 200N if the efficiency of the machine is 90%. (3 mks)

.....

.....

.....

.....

.....

- c. An airtight flask containing a gas is connected to a mercury manometer. The levels of mercury in the two limbs of the manometer are as shown in the diagram below.

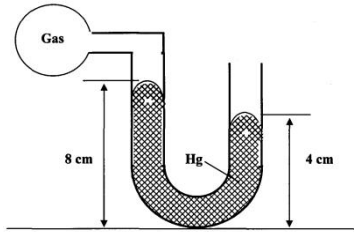

Calculate the pressure of the gas (Density of mercury = $1.36 \times 10^4 \text{ kg/m}^3$ and atmospheric pressure = $1.0 \times 10^5 \text{ N/m}^2$) (3mks)

.....

.....

.....

.....

.....

.....

d. State one way of making the surface tension of a liquid stronger. (1mk)

.....

.....

.....