

NAME _____ ADMNNO _____ CLASS _____

SCHOOL _____ DATE _____ SIGN _____

233/1

CHEMISTRY PAPER 1 THEORY

TIME: 2 HOURS

KCSE TOP PREDICTION MASTER CYCLE 2

Instructions to students

- Write your name, Admission number, school and class in the space provided above.
- All working must be shown clearly in the space provided.
- Non programmable silent electronic calculators may be used.
- Students should check the questions paper to ascertain that all the pages are printed.
- Students should answer the questions in English.
- Answer **ALL** questions in the spaces provided.

FOR EXAMINERS USE ONLY

QUESTION	MAXIMUM SCORE	CANDIDATES' SCORE
1-28	80	

1. Using reagents provided only, explain how you could prepare a salt of Zinc carbonate solid. Dilute nitric(v) acid, zinc, sodium carbonate (3mks)

.....
.....

2. The diagram below shows a Bunsen burner when in use

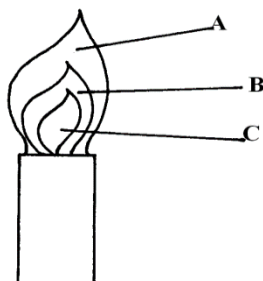

Describe an experiment that would confirm that region labeled C is unsuitable for heating. (2mks)

.....
.....

3. a) On the grid provided sketch a graph of pressure against volume for fixed mass of a gas at constant temperature (1mk)



b) A fixed mass of a gas has a volume of 250cm^3 at 27°C and 750mmHg pressure.

Calculate the gas volume that the gas would occupy at 41°C and 750mmHg pressure. ($0^\circ = 273\text{k}$)

(2mks)

.....
.....
.....
.....

4. 22.2cm^3 of sodium hydroxide solution containing 4.0g per litre sodium hydroxide were required for complete neutralisation of 0.1g of a dibasic acid. Calculate the relative formula mass of the dibasic acid. ($\text{Na} = 23, \text{O} = 16, \text{H} = 1$) *(3mks)*

5. The diagram below represents a laboratory experiment to investigate the reaction between hydrogen - sulphide gas and an aqueous iron (III) chloride.

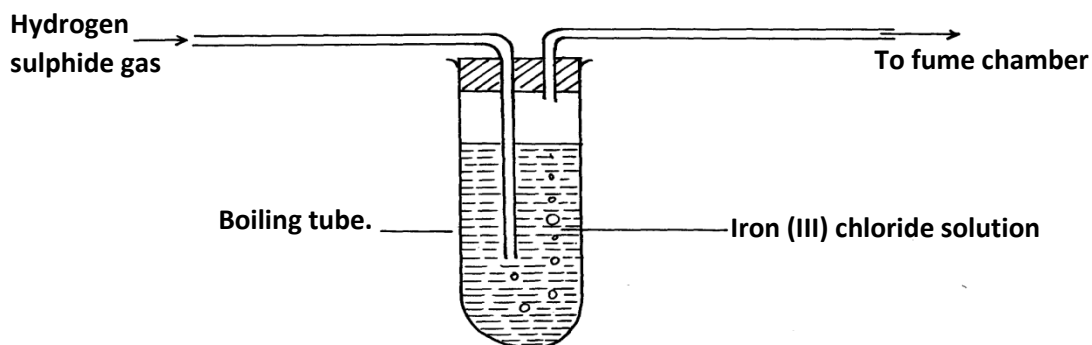

- a) Write chemical equation for the reaction which takes place in the boiling tube. (1mk)

.....

- b) What adjustment need to be made in the above set-up if the laboratory does not have a fume chamber. (1mk)

.....

- c) Describe a laboratory chemical test for a sample of hydrogen sulphide gas. (1mk)

.....

6. A group of compounds called chlorofluorocarbons have a wide range of uses but they have harmful effects on the environment. State and explain one harmful effect of chlorofluorocarbons on the environment. (2mks)

.....

.....
.....

7. X grams of a radioactive isotope takes 120 days to decay to 3.5 grams. The half-life period of the isotope is 20 days.

a) Calculate the initial mass of the isotope (2mks)

.....
.....

b) State the application of radioactivity in agriculture. (1mk)

8. Sulphur and sodium belong to the same period on the periodic table. State and explain the difference in M.P of the oxide of sulphur and the oxide of sodium. (3mks)

.....
.....
.....
.....

9. a) Water is an example of a polar solvent. What is a polar solvent? (1mk)

.....
.....

b) Explain the following observations HCl gas dissolves in water to form an electrolyte, while the same chloride dissolves in methylbenzene to form a non-electrolyte (1mk)

.....
.....

10. a) Define the term deposition

(1mk)

.....
.....

b) Describe how you can obtain copper powder from a mixture containing copper and zinc powder. (2mks)

.....
.....
.....
.....

11. a) Name the main ore from which iron is extracted.

(1mk)

.....
.....

b) Name two substances that convert iron (III) oxide to iron in the blast furnace. (2mks)

.....
.....

12. a) Write an equation showing how boiling can remove temporary water hardness. (1mk)

.....
.....

b) Name one method that can be used to remove both temporarily and permanent water hardness. (1mk)

.....
.....

c) Other than wastage of soap during cleaning, state one other disadvantage of hard water. **(1mk)**

.....
.....

13. a) Name two pure allotropes of carbon. **(1mk)**

.....
.....

b) State and explain using relevant equations the observation made when carbon(IV) oxide is bubbled through calcium hydroxide solution for a long time. **(2mks)**

.....
.....
.....
.....

14. When $\text{Na}_2\text{CO}_3 \cdot x\text{H}_2\text{O}$ is strongly heated it loses 63.2% of its mass. Determine the value of x in the compound (Na = 23, O = 16, H = 1) **(3mks)**

.....
.....
.....
.....

15. Dry ammonia was passed over a heated lead(II) oxide in a combustion tube as shown

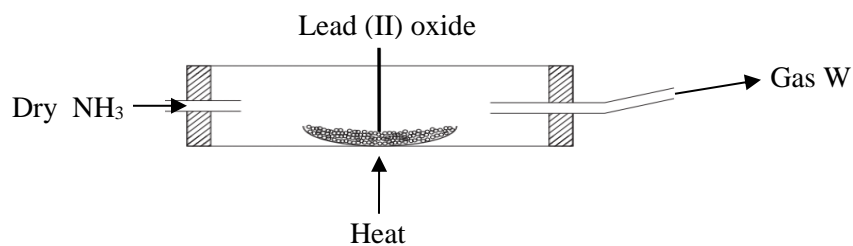

a) What observations would be made in the combustion tube (1mk)

.....
.....

b) Write a chemical equation for the reaction in the combustion tube (1mk)

.....
.....

c) State one industrial use of ammonia (1mk)

.....
.....

16. An ion of P²⁺ has a configuration of 2.8

a) Name the family to which P belong (1mk)

b) Compare the atomic and ionic radius of P. Explain (2mks)

17. a) Explain why alkanes are used as fuel (1mk)

.....
.....

b) Draw the structure of the following compounds (2mks)
i) 3-methylbut – 1 yne

ii) But – 2 –ene

18. a) Define solubility (1mk)

.....
.....

b) Study the information in the table and answer the questions below

Salt	Solubility (g) 100g water	
	At 40 ⁰ C	At 60 ⁰ C
CUSO ₄	28	38
Pb(NO ₃) ₂	79	98

i) Calculate the mass of CuSO₄ that would saturate 200g of water at 60⁰C (1mk)

.....
.....

ii) A solution containing 80g of Pb(NO₃)₂ in 100g of water at 60⁰C was cooled to 40⁰C.
Calculate the mass of Pb(NO₃)₂ that crystallized (1mk)

.....
.....

19. Dilute hydrochloric acid was added to a compound Z of copper. The solid reacted with the acid to form a colourless gas which formed a white precipitate when bubbled through lime water.

a) Name solid Z

..... (1mk)

b) State the observation that would be made if a similar compound of lead is used.
Explain. (2mks)

.....
.....

20. a) Explain why the reactivity of group(VII) elements decrease down the group (2mks)

.....
.....

b) Moist blue litmus and dry blue litmus paper were introduced into gas jars of dry chlorine. State the observations that would be made. (1mk)

.....
.....

21. a) Name the reagents that are commonly used in the preparation of hydrogen (1mk)

.....
.....

b) Study the diagram below and answer the questions that follow

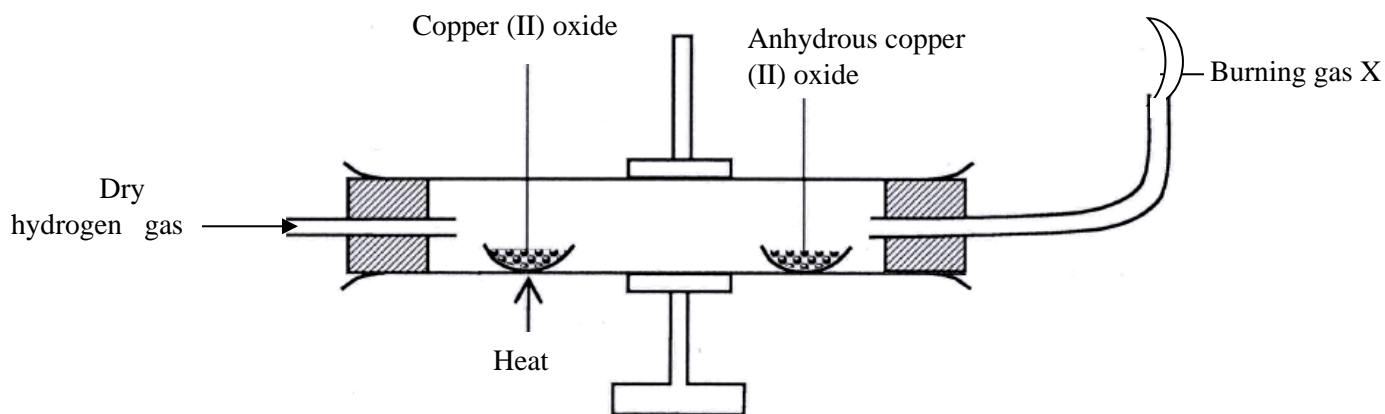

i) Name gas x (1mk)

.....

ii) State and explain the observation made in the anhydrous copper(II) sulphate after sometime (1mk)

.....

22. a) State two physical properties of sulphur (IV) oxide (1mk)

.....

b) Explain why when sulphur (IV) oxide is bubbled into acidified potassium dichromate (VI) the solution changes colour from orange to green. Explain the observation (1mk)

.....

c) In the contact process of manufacture of sulphuric(VI) acid, explain how pollution by SO_2 is reduced. (1mk)

.....
.....

23. Study the setup below and answer questions that follow

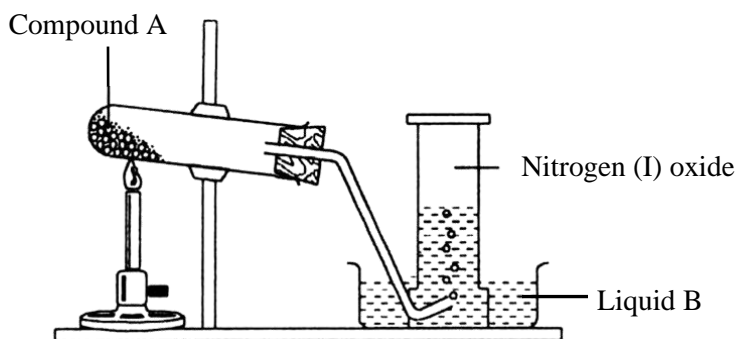

a) Name (1mk)

i) Compound A

.....

ii) Liquid B

.....

b) Why is the boiling tube tilted downwards (1mk)

.....

24. Explain why

a) Aluminium is commonly used for making cooking pots and pans. (1mk)

.....
.....

b) Silicon(IV) oxide is a poor conductor of heat and electricity (1mk)

.....
.....

25. The set up below was used to show electrolysis in molten lead(II) iodide

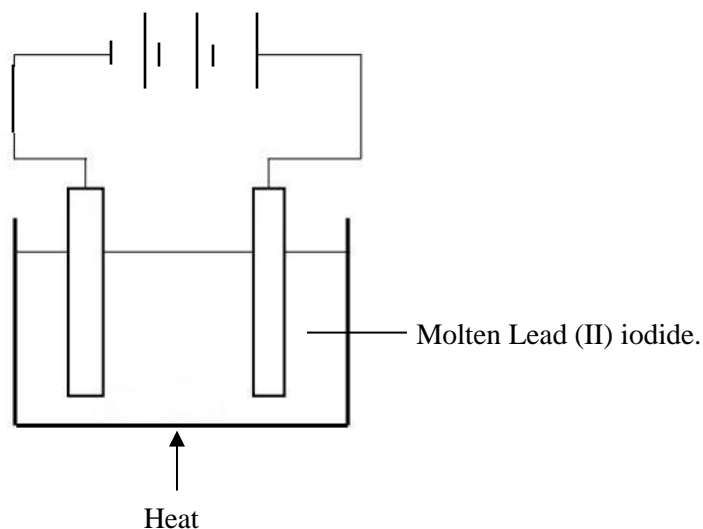

- i)* On the diagram label the cathode *(1mk)*

- ii)* State the observation that was made at the anode during the electrolysis. Give a reason for your answer *(2mks)*

.....
.....
...

26. 100cm^3 of carbon (II) oxide gas was reacted with 100cm^3 of oxygen. (All volume were measured under the same conditions of temple and pressure.

- a) Determine
 - i) Volume of the product formed *(1mk)*

 - ii) The gas which was in excess and by what volume *(2mks)*

.....
.....

27. a) Using a dot(.) and cross(x) diagram of carbon(II) oxide, differentiate between a covalent and a co-ordinate bond (1mk)

b) Use dot (.) and cross(x) diagrams to show bonding in between the elements represented by the following symbols.

(2mks)

i) $\begin{matrix} 24 \\ X \\ 12 \end{matrix}$ and $\begin{matrix} 19 \\ Y \\ 9 \end{matrix}$

28. Study the flow diagram below

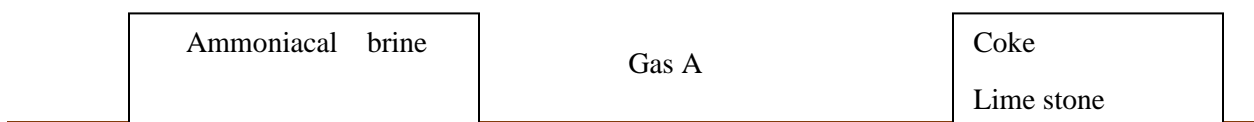

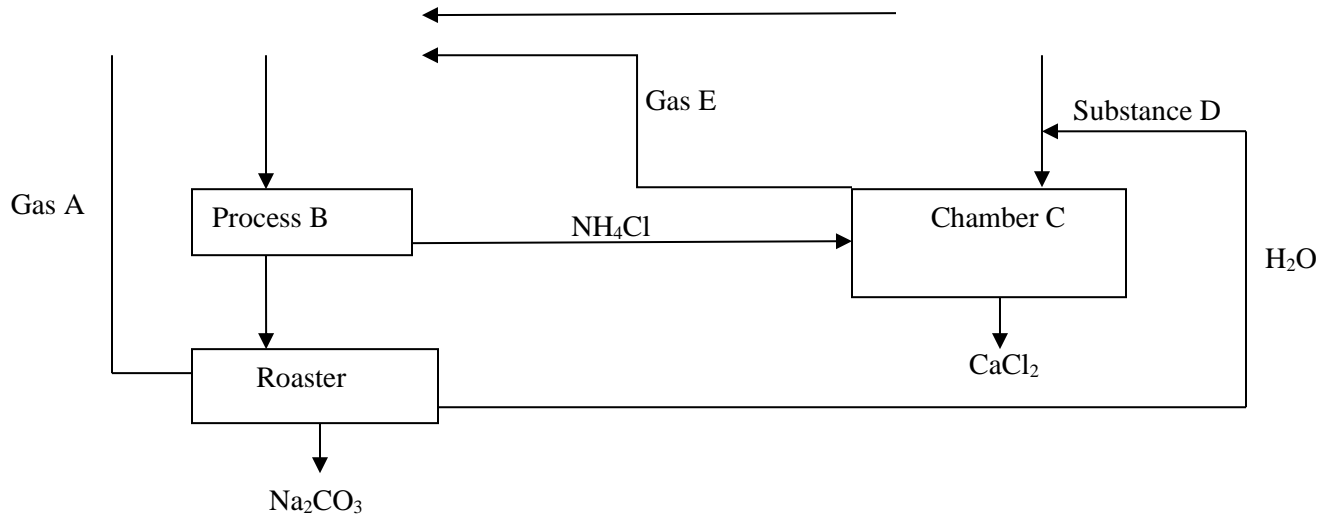

a) Name

i) Gas A (1/2 mk)

ii) Process B (1/2 mk)

iii) Substance D (1/2 mk)

iv) Gas E (1/2 mk)

b) Write the equation for the reaction in chamber C (1mk)

.....
