

KCSE 2023 PREDICTION CYCLES



GEOGRAPHY PAPER 1



KCSE 2023 TOP PREREDICTION CYCLE 1-10

CLASS OF KCSE 2023 NOVEMBER

The set Comprises of 10 Prediction Cycles prepared by a panel of Top Writers from KNEC Nairobi HQ

Kenya Educators Consultancy is proud to announce that in KCSE 2022 National Examination, More than 55% of our predictions from the same panelists appeared in the national exam (KCSE)

All KCSE 2023 November Candidates are advised to take the questions in this package of predictions serious as they prepare for the national exams!

FOR MARKING SCHEMES AND SIMILAR RESOURCES :

CONTACT:

MR MACHUKI - 0724333200

OR

ORDER ONLINE AT:

www.kenyaeducators.co.ke

Confidential!!!

All the best to all KCSE 2023 Candidates as they prepare for the national exams

KENYA EDUCATORS CONSULTANCY

NAME.....ADM NO.....CLASS.....
DATESIGN.....
SCHOOL

312/1
GEOGRAPHY
PAPER 1
TIME: 2 ¾ HOURS

KCSE TOP PREDICTION MASTER CYCLE 1

INSTRUCTIONS TO CANDIDATES.

Write your name, admission number and class

- This paper has **two** sections **A** and **B**
- Answer **ALL** the questions in section **A**.
- In section **B** answer questions **6** and any other **TWO** questions.
- Candidates should check to ascertain that all pages are printed and that no questions are missing.

SECTION A	
QUESTION 6	
QUESTION 7	
QUESTION 8	
QUESTION 9	
QUESTION 10	
TOTAL	

Compiled and Distributed by Kenya Educators Consultancy, P.O.BOX 15400-00500,
Nairobi.

Tel 0724333200 E-mail kenyaeducators@gmail.com. ORDER MARKING SCHEMES AT
www.kenyaeducators.co.ke or Contact 0724333200/0768321553/0795491185

SECTION A (25MARKS)

Answer ALL questions in this section

1 Name two branches of geography (2mks)

(b) Give three reasons why it is important to study geography. (3mks)

2(a) State two characteristic of the core of the earth. (2mks)

(b) The diagram below shows the angles of the sun rays at different latitudes when the sun is at the equator. Use it to answer the question (i) and (ii)

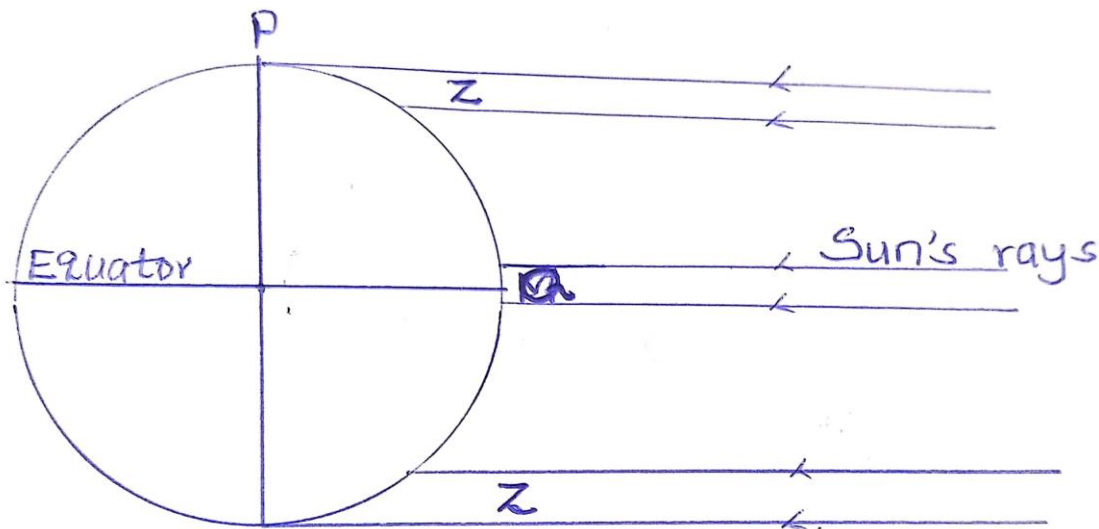

(i) Name the part of the earth surface marked p (1 mark)

(ii) Give two reasons why the intensity of the insolation is higher at Q than Z? (2mks)

3. (a) The table below shows some original rock and their corresponding metamorphic rocks.

Original rock	Metamorphic rock
(i)	Marble
Clay	Slate
Granite	Gneiss
Graphite	(ii)

Identify the rocks (i) and (ii) (2mks)

b) State 3 significance of rocks (3marks)

4. (i) Identify two fold mountains in Africa. (2mks)

(ii) The diagram below shows asymmetrical fold. Name the labelled parts A and B (2m)

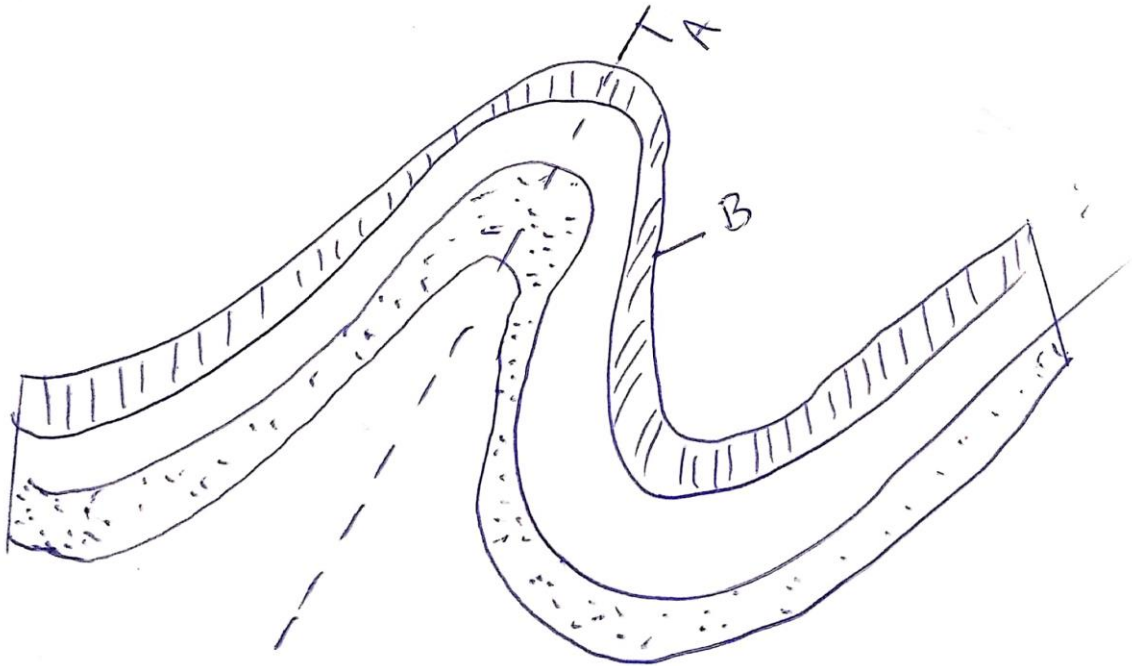

5. (a) State three conditions necessary for the development of karst scenery. (3mks).

(b) In which three ways is underground water significant to human activities? (3mks)

SECTION B: 75 MARKS

Answer question 6 and any other TWO questions from this section.

6. Use the map extract Yimbo (1:50,000) sheet 115/1 provided, to answer the questions that follows.

a (i) What is the latitudinal extent of the area covered by the map ? (2mks)

(ii) What is the direction of Maranda school from Yalombo island ? (1mks)

(iii) Calculate the area of Mageta island (2mks)

Compiled and Distributed by Kenya Educators Consultancy, P.O.BOX 15400-00500,
Nairobi.

Tel 0724333200 E-mail kenyaeducators@gmail.com. ORDER MARKING SCHEMES AT
www.kenyaeducators.co.ke or Contact 0724333200/0768321553/0795491185

(i) Identify two manmade features in the grid square 2293. (2mks)

b (i) Describe the relief of the area covered by the map. (4mks)

(ii)What is the bearing of the water whole in grid reference 2882 from trigonometric station in grid square 3285 (2mks)

(iii)Giving evidence, identify three social services provided in the area covered by the map. (6mks).

c(i) Draw a rectangle 8 cm by 4.5 cm to represent the area between easting 09 and 17, and between northing 84 and 87 (2mks)

On the rectangle show

-Internal boundary (1mk)

-Mageta island (1mk)

d. Identify two methods used to represent relief in the area covered by the map (2mks)

7a(i)Name three types of faults (3mks)

(ii)Apart from compressional forces, explain two other processes that may cause faulting. (4mks)

b) With the aid of diagrams ,describe how compressional forces may have led to the formation of the Great Rift Valley. (8mks)

c) Explain five ways in which faulting is of significance to human activities. (10mks)

8(a) Name two processes of wind erosion in hot desert areas (2mks)

b) Describe how the following factors influence wind erosion on hot desert surface

Compiled and Distributed by Kenya Educators Consultancy, P.O.BOX 15400-00500,
Nairobi.

Tel 0724333200 E-mail kenyaeducators@gmail.com. ORDER MARKING SCHEMES AT
www.kenyaeducators.co.ke or Contact 0724333200/0768321553/0795491185

(i) Nature of rock material. (2mks)

(ii) Strength of wind. (2mks)

(iv) Absence of obstacles. (2mks)

c) With the aid of well labelled diagrams describe how a rock pedestal is formed. (7mks)

d) (i) Suppose you are asked to carry out a field study on action of water in the desert .List two erosional features you are likely to study . (2mks)

(ii) Explain significance of resultant features of action of water and wind in arid areas (8mks)

9a (i) What is vegetation ? (2mks)

(ii) Explain how the following factors influence vegetation distribution on the surface of the earth (8mks)

(i) Relief.

(ii) Aspect

(iii) Drainage.

(iv) Human activities.

b) State four characteristics of tropical rainforest (4mks)

(ii) Explain three causes of decline of areas under forests in Kenya (6mks)

c. You carried out a field study on vegetation in the area neighbouring your school.

(i) State two objectives you would have for the study. (2mks)

(ii) Identify three uses of vegetation you are likely to have identified. (3mks)

Compiled and Distributed by Kenya Educators Consultancy, P.O.BOX 15400-00500,
Nairobi.

Tel 0724333200 E-mail kenyaeducators@gmail.com. ORDER MARKING SCHEMES AT
www.kenyaeducators.co.ke or Contact 0724333200/0768321553/0795491185

- 10.a (i)What is a glacier (2mks)
- ii)Name two mountains in East Africa which are ice capped (2mks)
- b(i) Identify and explain three processes of glacial movements (6mks)
- (c).Explain how a cirque lake is formed (5mks)
- (d)Students from Narumoru were required to carry out a field study on glaciation features on Mt. Kenya
- (i)Formulate two hypotheses for their study (2mks)
- (ii)Identify two methods they would use to record data (2mks)
- (iii)Give three follow up activities students would undertake after field study. (3mks)
- (v)State three problems likely to have been encountered during the field study (3mks)

Compiled and Distributed by Kenya Educators Consultancy, P.O.BOX 15400-00500,
Nairobi.

Tel 0724333200 E-mail kenyaeducators@gmail.com. ORDER MARKING SCHEMES AT
www.kenyaeducators.co.ke or Contact 0724333200/0768321553/0795491185

NAME:INDEX NO:

DATE:.....CLASS.....SIGN.....

SCHOOL.....

311/1

GEOGRAPHY

PAPER 1

TIME: 2 ¾ HOURS

KCSE TOP PREDICTION MASTER CYCLE 2

INSTRUCTIONS TO CANDIDATES

This paper has two sections A and B

Answer all questions in section A

In section B answer question 6 and any two questions

All answers must be written in English in the booklet provided

Compiled and Distributed by Kenya Educators Consultancy, P.O.BOX 15400-00500,
Nairobi.

Tel 0724333200 E-mail kenyaeducators@gmail.com. ORDER MARKING SCHEMES
AT

www.kenyaeducators.co.ke or Contact 0724333200/0768321553/0795491185

SECTION A

ANSWER ALL THE QUESTIONS IN THIS SECTION

1.a)What is the difference between a meteor and a meteorite (2mks)

.....
.....
.....
.....
.....

b)State three effects of earth’s revolution (3mks)

.....
.....
.....
.....
.....
.....
.....
.....
.....

2.a)List two elements of weather(2mks)

.....
.....
.....
.....

**Compiled and Distributed by Kenya Educators Consultancy, P.O.BOX 15400-00500,
Nairobi.**

**Tel 0724333200 E-mail kenyaeducators@gmail.com. ORDER MARKING SCHEMES
AT**

www.kenyaeducators.co.ke or Contact 0724333200/0768321553/0795491185

b)Name three processes through which the atmosphere is heated (*3mks*)

.....

.....

.....

.....

.....

.....

.....

.....

.....

.....

.....

.....

3a)What is weathering (*2mks*)

.....

.....

.....

.....

.....

b)Give three processes of chemical weathering (*3mks*)

.....

.....

.....

.....

.....

.....

.....

.....

.....

.....

.....

Compiled and Distributed by Kenya Educators Consultancy, P.O.BOX 15400-00500,
Nairobi.

Tel 0724333200 E-mail kenyaeducators@gmail.com. ORDER MARKING SCHEMES

AT

www.kenyaeducators.co.ke or Contact 0724333200/0768321553/0795491185

4a) Name three types of coral reefs (*3mks*)

.....

.....

.....

.....

.....

.....

.....

.....

.....

.....

.....

b) What are the benefits of coral reefs in the areas they have developed (*2mks*)

.....

.....

.....

.....

.....

5a) State two factors which influence occurrence of surface run-off (*2mks*)

.....

.....

.....

.....

.....

.....

.....

Compiled and Distributed by Kenya Educators Consultancy, P.O.BOX 15400-00500,
Nairobi.

Tel 0724333200 E-mail kenyaeducators@gmail.com. ORDER MARKING SCHEMES

AT

www.kenyaeducators.co.ke or Contact 0724333200/0768321553/0795491185

b)The diagram below shows a waterfall. Name the features marked X,Y, and Z (3mks)

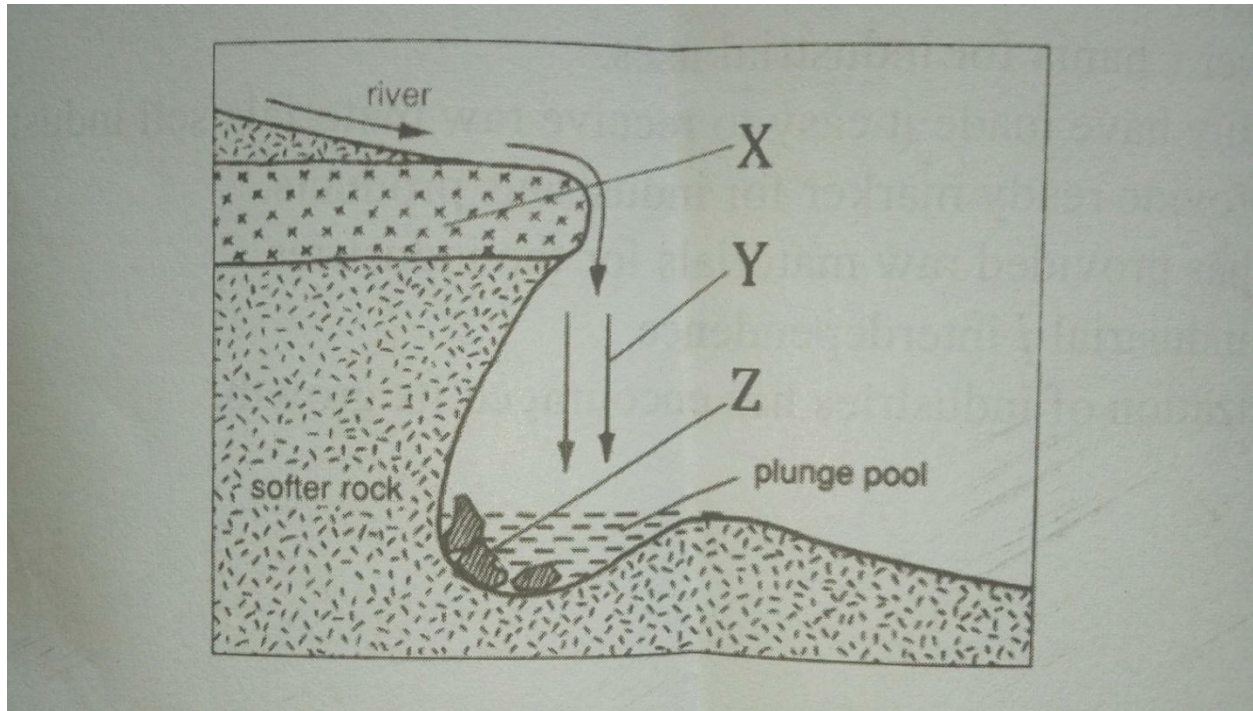

Compiled and Distributed by Kenya Educators Consultancy, P.O.BOX 15400-00500,
Nairobi.

Tel 0724333200 E-mail kenyaeducators@gmail.com. ORDER MARKING SCHEMES
AT

www.kenyaeducators.co.ke or Contact 0724333200/0768321553/0795491185

SECTION B
ANSWER QUESTION 6 AND ANY OTHER TWO QUESTIONS FROM THIS SECTION

6. Study the map of Taita hills (scale 1:50,000) provided and answer questions while follows.

Ai) Give the latitudinal position of the South Eastern corner of the map extract
(2mks)

.....
.....
.....
.....
.....
.....
.....
.....
.....
.....

ii) State the four figure grid reference of the school at Mrabenyi (1mk)

.....
.....
.....

iii) Identify the adjoining sheet number to the S.E of Taita hills (*1mk*)

.....
.....

Bi) Measure the length of dry weather road D535 from the junction at grid 4028 to the east of the map (*2mks*)

.....
.....
.....

ii) Calculate the area enclosed by the railway line to the south Eastern part of the map (*2mks*)

.....
.....
.....
.....

Ci) Reduce the square enclosing Easting 37 to 42 and Northing 26 to 31 by 2, on the reduce square indicate the following.

-Ronge forest

-Road D535

-Outcrop rock (*5mks*)

Compiled and Distributed by Kenya Educators Consultancy, P.O.BOX 15400-00500, Nairobi.

Tel 0724333200 E-mail kenyaeducators@gmail.com. ORDER MARKING SCHEMES AT

www.kenyaeducators.co.ke or Contact 0724333200/0768321553/0795491185

ii) Give the new scale of the reduced square (*2mks*)

.....
.....
.....
.....
.....
.....
.....
.....
.....

Di) Describe the drainage of the area covered by the map (*4mks*)

.....
.....
.....
.....
.....
.....
.....
.....
.....

ii) Identify two methods of representing relief used in the map extract (*2mks*)

.....
.....
.....
.....
.....
.....

Compiled and Distributed by Kenya Educators Consultancy, P.O.BOX 15400-00500,
Nairobi.

Tel 0724333200 E-mail kenyaeducators@gmail.com. ORDER MARKING SCHEMES

AT

www.kenyaeducators.co.ke or Contact 0724333200/0768321553/0795491185

iii)Citing evidence from the map give two economic activities carried out (*4mks*)

.....
.....
.....
.....
.....
.....

7ai)What is artesian well? (*2mks*)

.....
.....
.....
.....
.....

ii)List four conditions necessary for the formation of an artesian well.(*4mks*)

.....
.....
.....
.....
.....
.....
.....
.....
.....
.....

**Compiled and Distributed by Kenya Educators Consultancy, P.O.BOX 15400-00500,
Nairobi.**

**Tel 0724333200 E-mail kenyaeducators@gmail.com. ORDER MARKING SCHEMES
AT**

www.kenyaeducators.co.ke or Contact 0724333200/0768321553/0795491185

b)With the aid of a well labeled diagram, describe the three zones of underground water(*6mks*)

Compiled and Distributed by Kenya Educators Consultancy, P.O.BOX 15400-00500,
Nairobi.

Tel 0724333200 E-mail kenyaeducators@gmail.com. ORDER MARKING SCHEMES
AT

www.kenyaeducators.co.ke or Contact 0724333200/0768321553/0795491185

ii) Identify three sources of underground waters (*3mks*)

.....

.....

.....

.....

.....

.....

.....

.....

.....

.....

.....

c) Explain three ways in which a Karst landscape would influence human activities (*6mks*)

.....

.....

.....

.....

.....

.....

.....

.....

.....

.....

.....

.....

.....

.....

.....

.....

.....

.....

.....

.....

.....

.....

Compiled and Distributed by Kenya Educators Consultancy, P.O.BOX 15400-00500, Nairobi.

Tel 0724333200 E-mail kenyaeducators@gmail.com. ORDER MARKING SCHEMES AT

www.kenyaeducators.co.ke or Contact 0724333200/0768321553/0795491185

d)Your class intends to carry out a field study on limestone area near your school
i)Name two surfaces features you are likely to identify (*2mks*)

.....
.....
.....
.....
.....

ii)State two problems you are likely to identify (*2mks*)

.....
.....
.....
.....
.....

8a)i)Define the term glaciation *2mks*

.....
.....
.....
.....
.....

ii)Name three types of glaciers *3mks*

.....
.....
.....
.....
.....
.....

Compiled and Distributed by Kenya Educators Consultancy, P.O.BOX 15400-00500,
Nairobi.

Tel 0724333200 E-mail kenyaeducators@gmail.com. ORDER MARKING SCHEMES
AT

www.kenyaeducators.co.ke or Contact 0724333200/0768321553/0795491185

b) Describe how the following features found in upland glaciated landscape are formed

i) U-shaped valley (*5mks*)

.....
.....
.....
.....
.....
.....
.....
.....
.....
.....
.....
.....
.....
.....
.....
.....
.....
.....
.....
.....
.....

Pyramidal peak (*5mks*)

.....
.....
.....
.....
.....
.....
.....
.....
.....
.....
.....
.....
.....
.....
.....
.....
.....
.....
.....
.....
.....

c) Explain three significance of upland glaciated features to human activities (**6mks**)

.....

.....

.....

.....

.....

.....

.....

.....

.....

.....

.....

.....

.....

.....

.....

.....

.....

.....

.....

.....

.....

.....

.....

d) Suppose you were to carry out a field study of a glaciated lowland

i) State two advantages of using oral interview to collect information during the field study (**2mks**)

.....

.....

.....

.....

.....

.....

.....

.....

.....

.....

.....

ii) Name two features found in glaciated lowlands that you are likely to study (**2mks**)

.....

.....

.....

.....

.....

.....

.....

.....

.....

.....

9ai) Differentiate between a soil profile and soil catena (2mks)

.....

.....

.....

.....

.....

.....

.....

.....

.....

.....

ii) Draw a well labeled diagram of a mature soil profile (4mks)

Compiled and Distributed by Kenya Educators Consultancy, P.O. BOX 15400-00500,
Nairobi.

Tel 0724333200 E-mail kenyaeducators@gmail.com. ORDER MARKING SCHEMES

AT

www.kenyaeducators.co.ke or Contact 0724333200/0768321553/0795491185

bi)Other than topography name three factors that influence formation of soil(4mks)

.....

.....

.....

.....

.....

.....

.....

.....

.....

.....

.....

.....

ii)Explain how topography influences formation of soil (3mks)

.....

.....

.....

.....

.....

.....

.....

.....

.....

.....

.....

Compiled and Distributed by Kenya Educators Consultancy, P.O.BOX 15400-00500,
Nairobi.

Tel 0724333200 E-mail kenyaeducators@gmail.com. ORDER MARKING SCHEMES

AT

www.kenyaeducators.co.ke or Contact 0724333200/0768321553/0795491185

iii)List three characteristics of desert soils (*3mks*)

.....

.....

.....

.....

.....

.....

.....

.....

.....

.....

.....

.....

ci)Give three types of soil erosion (*3mks*)

.....

.....

.....

.....

.....

.....

.....

.....

.....

.....

.....

ii) Explain three effects of soil erosion on human activities (*6mks*)

.....

.....

.....

.....

.....

.....

.....

.....

.....

.....

.....

.....

.....

.....

.....

.....

.....

.....

.....

.....

.....

.....

10a)The diagram below represents zones of natural vegetation on a mountain within tropical regions, use it to answer questions (a) and (b)

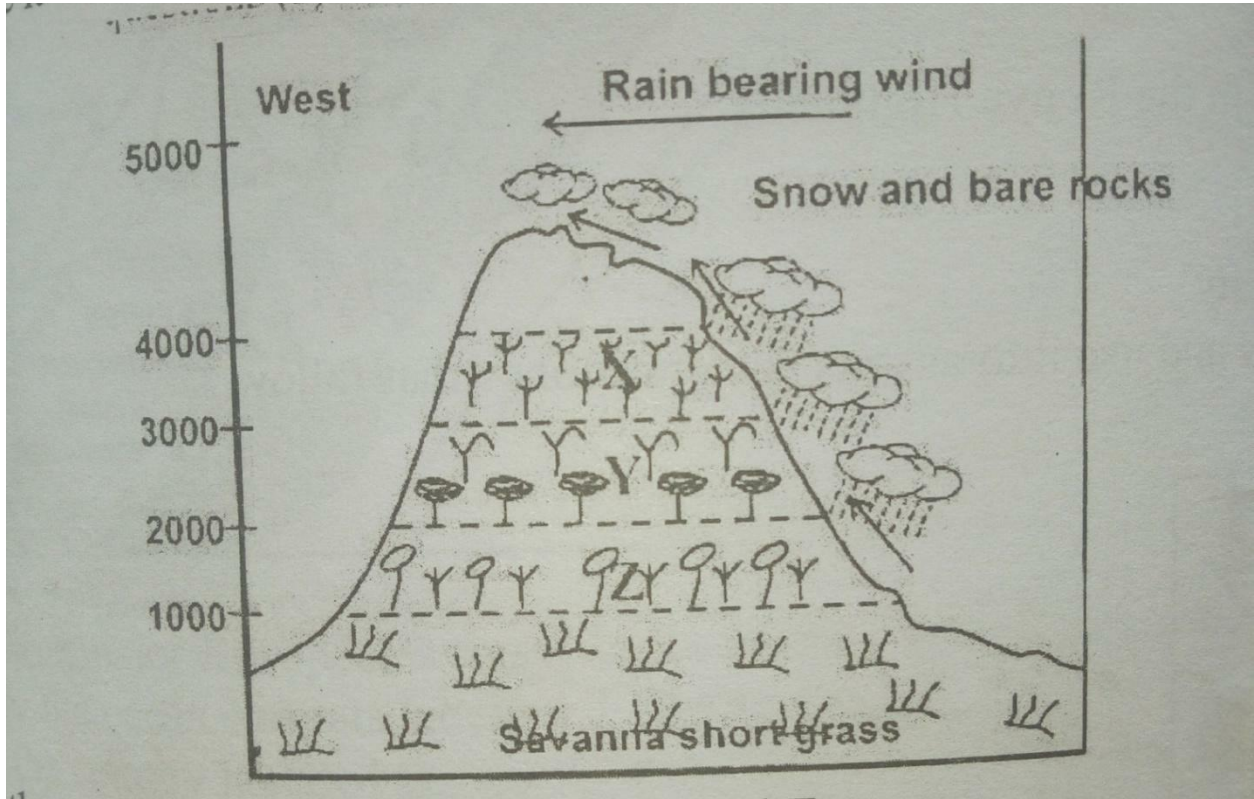

i)Name the vegetation zones marked X,Y and Z (3MKS)

.....

.....

.....

.....

.....

.....

Compiled and Distributed by Kenya Educators Consultancy, P.O.BOX 15400-00500, Nairobi.

Tel 0724333200 E-mail kenyaeducators@gmail.com. ORDER MARKING SCHEMES AT

www.kenyaeducators.co.ke or Contact 0724333200/0768321553/0795491185

ii) Give two reasons why the mountain top has no vegetation (*2mks*)

.....
.....
.....
.....
.....
.....

b) Describe the characteristics of savanna grasslands (*4mks*)

.....
.....
.....
.....
.....
.....
.....
.....
.....
.....
.....
.....
.....
.....
.....
.....
.....
.....

c) Explain four factors that have led to the decline of natural grassland in Kenya
(8mks)

.....
.....
.....
.....
.....
.....
.....
.....
.....
.....
.....
.....
.....
.....
.....
.....
.....
.....
.....
.....
.....
.....
.....

d) You carried out a field study of different tree species

i) Identify three activities you would carry out during the field study(3mks)

.....
.....
.....
.....
.....
.....
.....
.....
.....
.....
.....
.....

Compiled and Distributed by Kenya Educators Consultancy, P.O.BOX 15400-00500,
Nairobi.

Tel 0724333200 E-mail kenyaeducators@gmail.com. ORDER MARKING SCHEMES
AT

www.kenyaeducators.co.ke or Contact 0724333200/0768321553/0795491185

ii)How would you identify the different tree species?(3mks)

.....
.....
.....
.....
.....
.....
.....
.....
.....
.....

iii)State two methods you would use to determine the height of the trees (2mks)

.....
.....
.....
.....
.....
.....
.....

Compiled and Distributed by Kenya Educators Consultancy, P.O.BOX 15400-00500,
Nairobi.

Tel 0724333200 E-mail kenyaeducators@gmail.com. ORDER MARKING SCHEMES

AT

www.kenyaeducators.co.ke or Contact 0724333200/0768321553/0795491185

NAME.....

SCHOOL.....

ADM NO..... DATE.....

STUDENT'S SIGN.....

GEOGRAPHY

PAPER 1

Time: 2 ½ Hours

KCSE TOP PREDICTION MASTER CYCLE 3

INSTRUCTIONS

- Answer all questions in section A
- In section B answer question six and any other two questions

SECTION A

1. a) Differentiate between relative humidity and absolute humidity *(2mks)*
b) State three significance of water vapour in the atmosphere *(3mks)*
2. a) What do you understand by the term vertical Earth movement. *(2mks)*
b) Identify three causes of earth movements *(3mks)*
3. a) Give two process of slow mass movement. *(3mks)*
b) State two physical conditions that may influence landslides *(2mks)*
4. (a) State two factors that may determine the amount of surface run-off *(2mks)*
b) Use the diagram below to answer questions (i) and (ii)

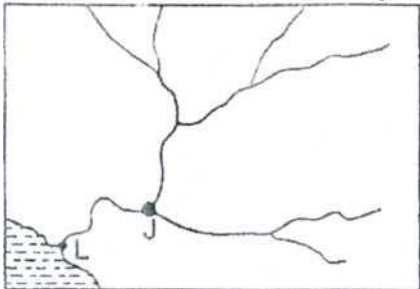

- Name part labelled J and L *(2mks)*
5. a) Define the term oceans *(2mks)*
b) State three reasons why ocean water are salty *(3mks)*

SECTION B

Answer question 6 and two other questions in this section

6. Use the map of Oyugis (1:50,000) sheet 130/1 provided, to answer the questions that follow

a. (i) Give two adjoining index to the south and East of oyugis map **(2mks)**

ii) Convert the scale of the map extract given 1:50000 into a statement scale

(b) What is the bearing, distance and direction of the trigonometrical station Ingrid square 7030 from brickworks in grid square 7832

(3mks)

(c) Enlarge by two area bounded by easting 85 and 88, northing 39 and 41

(2mks)

On it label and name the following

i) River Awach kasipul

(1mk)

ii) Forest boundary

(1mk)

iii) woodland

(d) Explain three factors that have favoured trade in the map extract.

(6mks)

(i) Citing evidence from the map state two social services offered in the area covered by Oyugis map

(2mks)

(ii) Describe the relief of the area covered by the map

(5mks)

7. (a) What is rotation of the Earth (2mks)

(b) The diagram below represents one effect resulting from rotation of the Earth. Use it to answer part (b(i) and (b(ii) below;

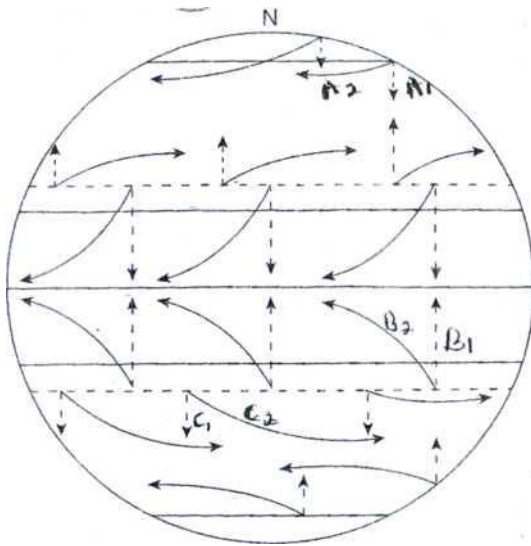

i) Name the effect of rotation represented by the diagram (1mk) (ii) Citing specific pressure zones and winds shown, describe the process represented in;

- (i) A1 and A2 (3mks)
- (ii) B1 and B2 (3mks)
- (iii) C1 and C2 (3mks)

(c) Explain how the following factors affects temperature

(i) Altitude (3mks)

(ii) Latitude (4mks)

d) Explain three reasons why a weather station must be sited away from tall building and trees **(6mks)**

8. (i) Name two types of vegetation .

(2mks)

II) Give two physiographic factors influencing vegetation distribution (2mks)

b) the diagram below shows vegetation zones of an East African mountain. Use it to answer questions below (bi) and b(ii)

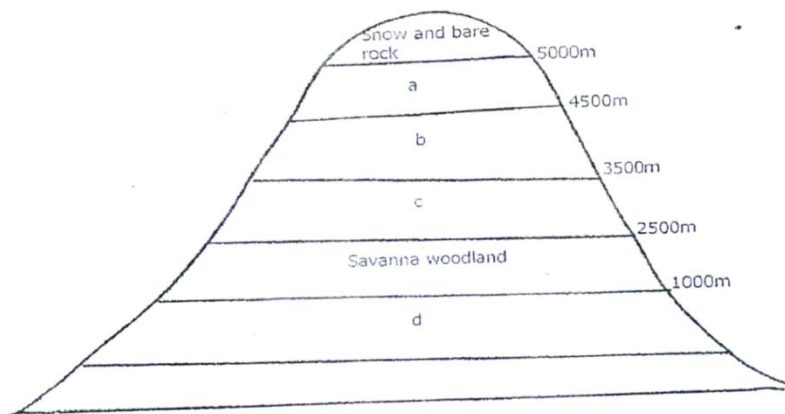

Name the zones a,b,c and d (4mks)

ii) Give one reason why there is no vegetation cover on the top of the mountain **(1mk)**

c (i) State the names given to temperate grassland vegetation in:

- North America
- Argentina

- ii) Explain three uses of savannah vegetation **(6mks)**
- d) Explain four characteristics of tropical desert vegetation **(8mks)**
9. (a) With the aid of well labelled diagram describe how a crag and tail is formed **(6mks)**
- (b) Name and describe four types of glacial moraines **(8mks)**
- C (i) Identify two features formed by glacial erosion in the highlands **(2mks)**
- (ii) State three factors which encourage glacial deposition **(3mks)**
- (iii) Explain three positive effects of glaciations to human activities **(6mks)**
10. (a) state **(3mks)**
- i) Three factors which contribute to the development of deserts **(3mks)**
- ii) Three processes through which winds erodes a desert land scape **(3mks)**
- b) Using well labelled diagrams explain how a rock pedestal is formed **(6mks)**
- c) Explain three significance of wind depositional features **(6mks)**
- d) Suppose you carry out a field study on the action of water in a desert
- i) List four features you are likely to study **(4mks)**
- ii) State three problems you are likely to experience during the field study **(3mks)**

NAME.....ADM NO.SIGN.....

SCHOOL.....CLASS..... DATE.....

312/1

GEOGRAPHY

PAPER ONE

TIME: 2 $\frac{3}{4}$ Hours

KCSE TOP PREDICTION MASTER CYCLE 4

INSTRUCTION

- a.) Write your name and index number
- b.) Sign and write the date of examination in the space provided above
- c.) This paper consists of two section A and B
- d.) Answer all section in the section A
- e.) Answer question 6 and any other two questions from section B
- f.) Answers must be written in the spaces provided at the end of question 5
- g.) This paper consists of 8 pages
- h.) Candidates must check all the Questions to ascertain that all pages are printed as indicated and no question is missing*
- (i) Candidates should answer all questions in English*

SECTION	QUESTION	MAXIMUM SCORE	CANDIDATE SCORE
A	1-5	25	
B	6	25	
		25	
		25	
		TOTAL SCORE	

SECTION A
ANSWER ALL QUESTIONS IN THIS SECTION

1. a) Define the term Geography (2mks)
- b) What is the relationship between Geography and Biology (2mks)
2. a) Use the diagram below to answer the following questions

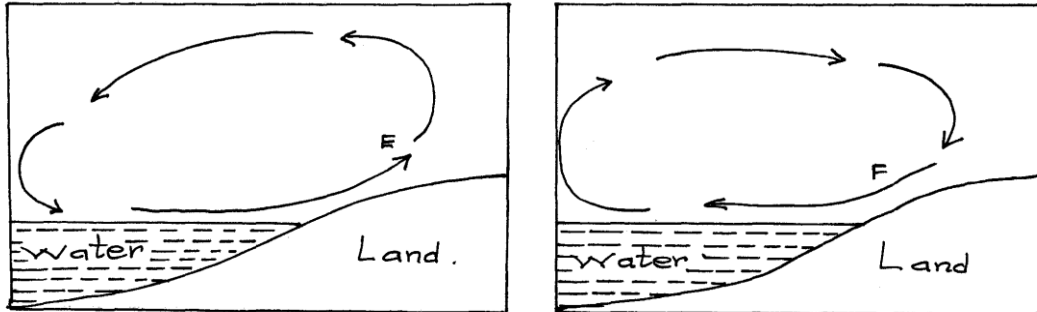

- i) Name the air currents marked E (1mk)
- ii.) Why is the air current marked F flow at night (3mks)
- b.) Give reason why air cools as it rises (2mks)
3. (a) Define folding (2mks)
- b.) List four types of folds (4mks)
- 4.) The diagram below illustrate a mass wasting process. Use it to answer question (a) and (b)

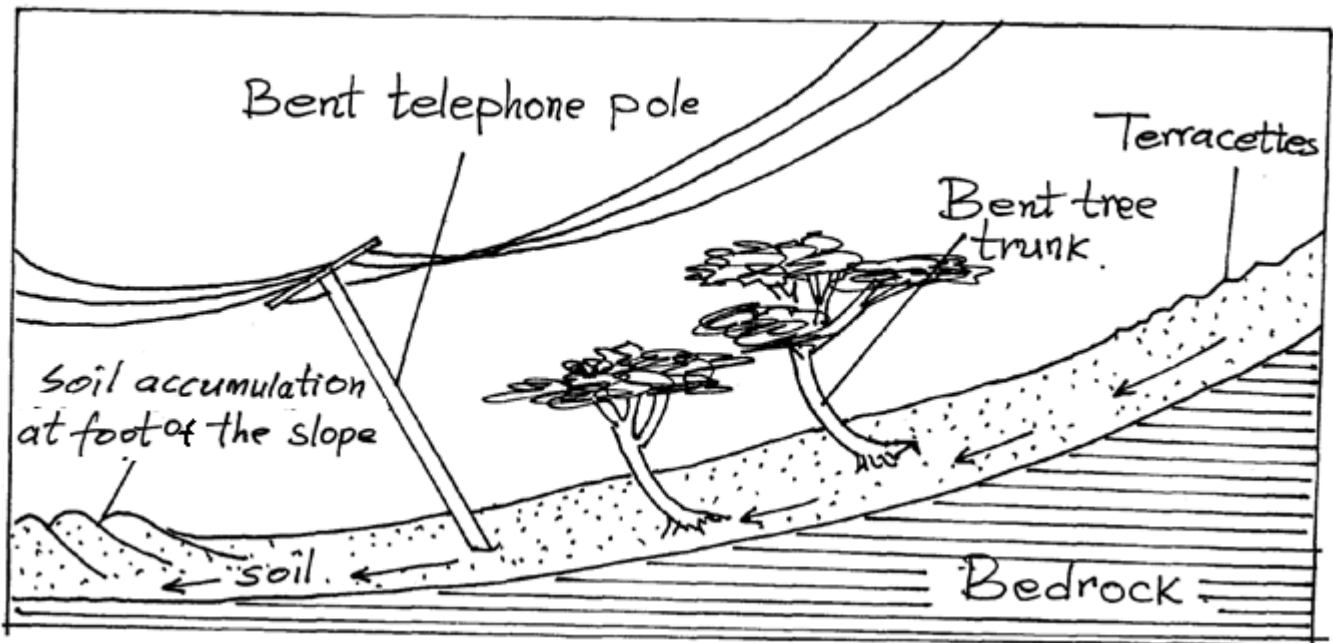

- a.) Identify the process (1mk)
- b.) Explain how the process occurs (3mks)
5. a.) What is a river profile (2mks)
- b.) Name the three stages of a river profile (3mks)

SECTION B

ANSWER QUESTION 6 AND OTHER TWO QUESTION FROM THIS SECTION

6. a. i.) Give the latitudinal and the longitudinal position of the south west corner of the map extract (2mks)
ii.) Calculate the magnetic declination of the map extract (2mks)
- b. i.) Which adjoining sheet is to the S.E of the area covered by the map? (1mk)
ii.) What is the general flow of river Chanya (2mks)
iii.) Give three social function of Nyeri town (3mks)
- c.) Calculate the area of Nyeri Forest to the East of Easting 69 and North of Northing 56. (Give your answer in Kilometre squared(Km²) (2mks)
- d.) Citing evidence from the map. Give
i.) Two reasons why the area is covered by the map is suitable for coffee growing (4mks)
ii.) Two factor that favor saw milling in the area covered by the map (4mks)
- e.) Describe drainage of the area covered by the map (5marks)
7. a. i.) Define the term rock (2mks)
ii.) Give two way of classifying rocks (2mks)
- b.) Describe the following characteristic of minerals (6mks)
 - Lustre
 - Colour
 - Hardness
- ii.) Give the changes that occur on sedimentary rocks when subjected to intense heat and pressure (4mks)
- c. i.) State the condition necessary for the growth of coral (3mks)
ii.) Describe how coral rocks are formed (4mks)
- d.) You are planning to carry out a field study on rocks
i.) List two methods of recording data you are likely to use (2mks)
ii.) Give two follow up activities of your study (2mks)
8. a.) What is Vulcanicity (2mks)
- b.) i.) Apart from Sill name other intrusive Volcanic features (3mks)
ii.) Describe how the following features are formed
 - A sill (5mks)
 - Hotspring (5mks)
- iii.) Differentiate between a lava and a magma (2mks)
iv.) Explain four negative effects of vulcanicity (8mks)
- 9.) a.) i.) What is the process through which wave transport the eroded materials along the coast (1mk)
ii.) Give three factors that influence wave deposition (3mks)
- b. i.) Name two types of submerged coast (2mks)
ii.) State three characteristic of emerged highland coast (3mks)
- c.) By the use of well labelled diagrams, describe the formation of a spit. (7mks)
- d.) Student from Moi secondary school were planning to conduct a field study on wave erosional features to areas along the coast.
i.) Give three activities they will undertake while in the field (3mks)
ii.) Name three erosional features they are likely to identify (3mks)
iii.) Outline three problems they are likely to face while in the field (3mks)
10. (a) (i) Identify two processes in which ice erodes (2mks)
ii.) Name four types of glacial moraine (4mks)
- b.) Give three ways in which ice moves (3mks)
- c. i.) Apart from Aretes, identify three other ice erosional features in highland areas (3mks)
ii.) Describe how an Aretes is formed (5mks)
- d.) Explain the significance of upland glaciated features to human activities (8mks)

KCSE TOP PREDICTION MASTER CYCLE 5

INSTRUCTIONS TO STUDENTS

- This paper has *two* sections A and B
- Answer *ALL* the questions in section A. In section B answer questions 6 and any other *TWO* questions.

SECTION A

Answer *all* the questions in this section.

- (a) State **three** reasons why it is important to study Geography. **(3 marks)**
 - (b) What is the relationship between Geography and Agriculture? **(2 marks)**
- (a) What is weather forecasting? **(2 marks)**
 - (b) List **three** elements of weather. **(3 marks)**
3. Study the diagram below and use it to answer questions (a) and (b) below:

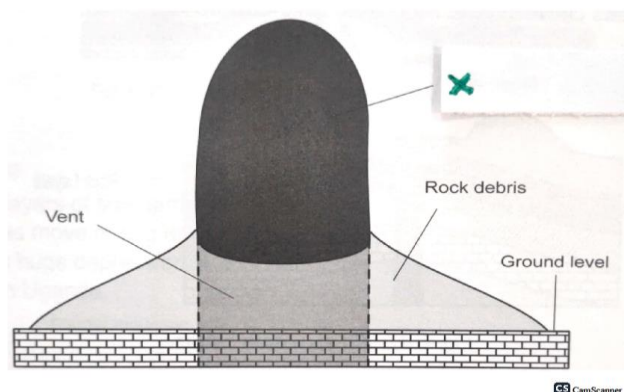

- (a) Identify the feature marked X. **(1 mark)**
 - (b) Describe how the feature is formed. **(4 marks)**
- (a) What is karst landscape? **(2 marks)**
 - (b) State **three** factors that influence the occurrence of underground water. **(3 marks)**

5. The diagram below shows lowland glaciated features. Study the diagram and answer questions (a) and (b).

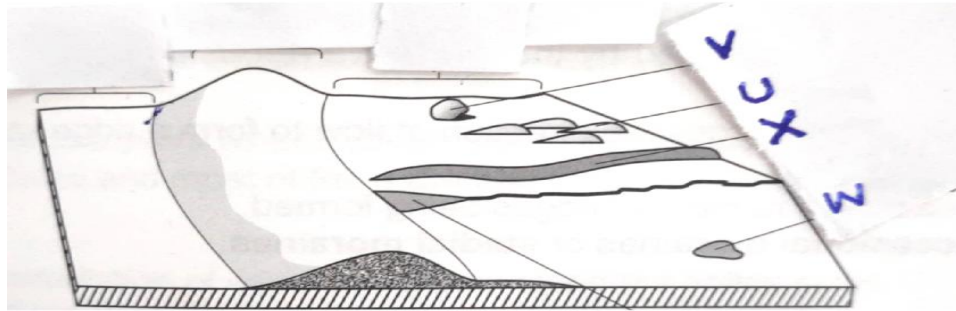

CS CamScanner

- (a) What is an outwash plain? (2 marks)
- (b) Name the features marked **U**, **V** and **W**. (3 marks)

SECTION B

Answer question 6 and any other TWO questions from this section.

6. Study the map of Nyeri **1:50000** (sheet **120/4**) provided and answer the following questions
- (a) (i) Name the **two** districts in the northern part of the map extract. (2 marks)
- (ii) Give the latitudinal extent of they are covered by the map. (2 marks)
- (iii) According to the marginal information provided in the map, what is the magnetic variation of the area when the map was drawn. (2 marks)
- (iv) Calculate the area of Nyeri forest on the map. Give your answer in square kilometres. (2marks)
- (b) Describe drainage of the area covered by the map. (5 marks)
- (c) Citing evidence from the map, explain **three** factors that favours the growing of coffee in Nyeri area. (6 marks)
- (c) Explain **three** factors that have influenced settlement in the area covered by the map. (6marks)
7. (a) (i) Differentiate between rocks and minerals. (2 marks)
- (ii) Describe the following characteristics of minerals.
- Color. (2 marks)
 - Hardness. (2 marks)
- (b) (i) What are igneous rocks? (2 marks)
- (ii) State **three** differences between plutonic and volcanic rocks. (3 marks)

- (c) Describe the formation of the following rocks.
- (i) Mechanically formed sedimentary rocks. **(3 marks)**
- (ii) Chemically formed sedimentary rocks. **(3 marks)**
- (d) (i) Identify the missing type of rocks. **(3 marks)**

Original rock	Metamorphic rock
Limestone	(i)
(ii)	Graphite
Granite	(iii)

- (ii) Suppose you were to carry out a field study on rocks at the Kenyan coast. State **two** reasons as to why you would ask for permission from the school administration. **(2marks)**
- (iii) What reasons would you give for the widespread of sedimentary rocks at the coastal plain? **(3marks)**
9. (a) (i) Name **three** types of river erosion **(3 marks)**
- (ii) Describe the following river erosional processes.
- Abrasion **(4 marks)**
 - Solution **(3 marks)**
- (b) (i) What is river rejuvenation **(2 marks)**
- (ii) Identify **three** features that result from river rejuvenation. **(3 marks)**
- (c) (i) Name **two** types of submerged highland coasts. **(2 marks)**
- (ii) State **two** factors influencing deposition by ocean waters. **(2 marks)**
- (d) Explain **three** significance of oceans to human activities. **(6 marks)**
10. (a) (i) Differentiate between soil texture and soil structure. **(2 marks)**
- (ii) Apart from living organisms, name **four** other components of soil. **(4 marks)**

- (b) The diagram below shows different layers of soil. Use it to answer questions (b) (i), (ii) and (ii)

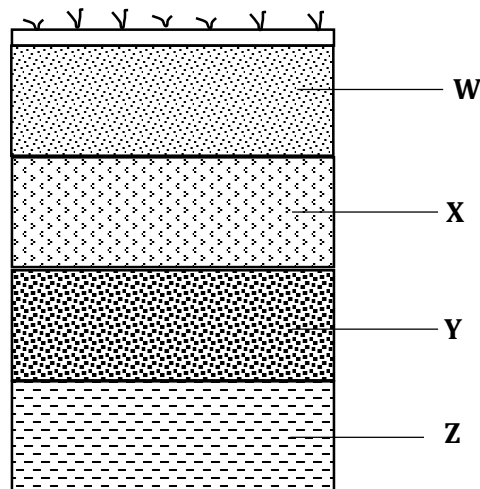

- (i) Name the soil layers **X**, **Y** and **Z** **(3 marks)**
- (ii) Give **two** main processes of soil formation which takes place in horizon W. **(2 marks)**
- (iii) State **four** characteristics of soil in horizon X. **(2 marks)**
- (c) Explain how the following farming practices may result to loss of soil fertility
- (i) Continuous irrigation. **(2 marks)**
- (ii) Over grazing. **(2 marks)**
- (iii) Over cultivation. **(2 marks)**
- (d) Explain ways in which natural vegetation may prevent soil from erosion. **(4 marks)**

NAME.....ADM NO.
CLASS DATE.....
SCHOOL

312/1

GEOGRAPHY

PAPER 1

2 ³/₄ HOURS

KCSE TOP PREDICTION MASTER CYCLE 6

INSTRUCTION TO CANDIDATES

1. Write your name and Index number in the spaces provided at the top of the page.
2. Answer all the questions in Section A. In section B answer question six and any other two questions from this section.
3. All answers must be written in the answer booklet provided.
4. This paper consist of four printed pages.
5. Candidates should check the question paper to ascertain that all page are printed as indicated and that no question is missing.

SECTION A

Answer all the questions in this section.

- 1 (a) Name two theories of the origin of the earth. (2marks)
- (b) State three effects of the rotation of the earth on its own axis. (3 marks)
- 2(a) State two ways in which underground water may reach the earth's surface (2marks).
- (b) Draw a well labelled diagram of the hydrological (5marks)
3. Give three reasons why the recording of data at a school weather may be inaccurate (3marks)
- 4 (a) What is natural vegetation? (2marks)
- (b) State **three** characteristics of the Mediterranean type of vegetation (3marks)
- 5(a) Name two major earthquake zones of the world (2marks)
- (b) Give **three** factors that influence the rate of weathering (3marks)

SECTION B

Answer question 6 and any other two questions from this section

- 6) Study the map of Nyeri 1:50,000 (sheet 120/4) provided and answer the following questions.
- a) i) What is the longitudinal extent of the map extract? (2marks)
- ii) Give the **Four** figure grid reference of the labour camp near Mweiga estate (2marks)
- iii) Identify **two** districts in the area covered by the map. (2marks)
- b) i) Give two methods used to represent relief on the map (2marks)
- ii) State three problems that maybe encountered during the construction of roads in the area covered by the map (3marks)
- c) Citing evidence from the map, give three reasons why cattle rearing is widespread in Nyeri area. (6marks)
- d) i) Apart from administration, give three other services provided in the area covered by Nyeri map
- ii) Describe the distribution of settlement in the area covered by the map (4marks).

iii) Give two factors that favour coffee growing in Nyeri Map (2marks)

7) (i) Apart from fold mountains, name three other features resulting from folding (3marks)

ii) On the outline map of Africa provided, name the feature marked x, y and z. (3marks)

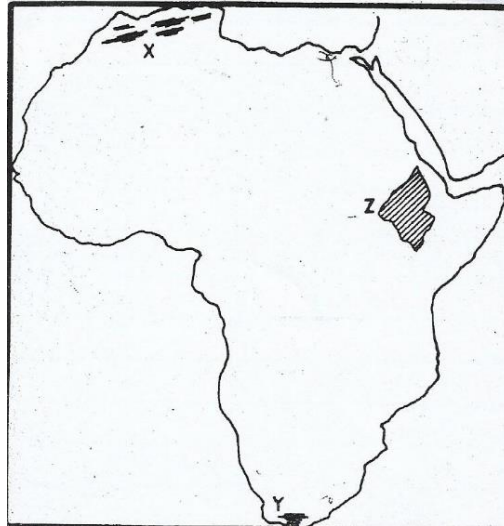

iii) Describe the formation of Fold Mountains (5marks)

c) (i) Name four major orogeny (4marks)

ii) Using a well labelled diagram describe the formation of an Asymmetrical fold (6marks)

(d) Explain two ways in which Fold Mountains influence climate (4marks)

8) a) (i) What is a river divide (2marks)

ii) Describe three ways by which a river transports its load. (6marks)

(b) Describe the characteristics of river in its old stage (4marks)

(c) Describe each of the following drainage patterns

i) Superimposed drainage pattern (3marks)

ii) Centripetal drainage pattern (2marks)

d) (i) What is a delta (2marks)

ii) The diagram below shows a section of a river. Use it to answer the questions that follow.

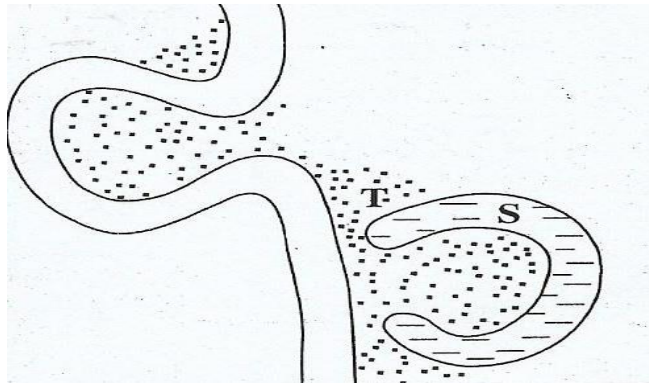

Name the features marked S and T (2marks)

iii) State four conditions that are necessary for the formation of the feature marked S. (4marks)

9 (a) Describe the following characteristics of minerals

i) Colour (2 marks)

ii) Cleavage (2marks)

iii) Hardness (2 marks)

b) (i) Give two types of igneous rocks (2marks)

iv) Explain three conditions necessary for the growth of coral polyps (3marks)

c) Describe three ways in sedimentary rocks are formed (9marks)

d) (i) What is rock metamorphism? (2marks)

(ii) State three causes of heat and pressure during metamorphism. (3marks)

10 a (i) What is soil catena (2marks)

(ii) Draw a labelled diagram to show a well develop soil profile. (5marks)

(iii) State three characteristics of soils found in the arid regions of Kenya (3marks)

(b) Give three factors that determine the colour of soils (3mks)

c) Describe how lateralization occurs (6marks)

d) Describe how the following types of erosion occur.

i) Sheet erosion (2marks)

ii) Gully erosion (2marks)

d) Give two factors that influence the thickness of a soil

(2marks)

THIS IS THE LAST PRINTED PAGE

NAME:Index No:
 SCHOOL
 CLASS DATESIGN

312/1
 GEOGRAPHY
 Paper 1
 Time: 2 ¾ Hours

KCSE TOP PREDICTION MASTER CYCLE 7

Instructions to Candidates:

- a) Write your name and admission number on the spaces provided above.
- b) This paper has **two** sections: **A** and **B**.
- c) Answer **all** questions in section **A**.
- d) In section **B**, answer **question 6** and any **other two** questions.

FOR EXAMINERS USE ONLY

SECTION A

Question number	1	2	3	4	5	Sub Total
Marks						

Grand total

SECTION B

Question number	6	7	8	9	10	Sub Total
Marks						

SECTION A

Answer ALL Questions in this Section

1. (a) What is a weather station? (2 marks)
(b) Give **three** factors that influence wind direction. (3 marks)

2. (a) Name **two** types of tectonic plate boundaries. (2 marks)
(b) Give **three** effects of the movement of tectonic plates. (3 marks)

3. (a) Give the difference between latitude and longitude. (2 marks)
(b) When the local time is 2:00pm at longitude 45E, what is the longitude of station A whose local time is 10:30am? (3 marks)

4. The diagram below shows a section of a river. Use it to answer the questions that follow

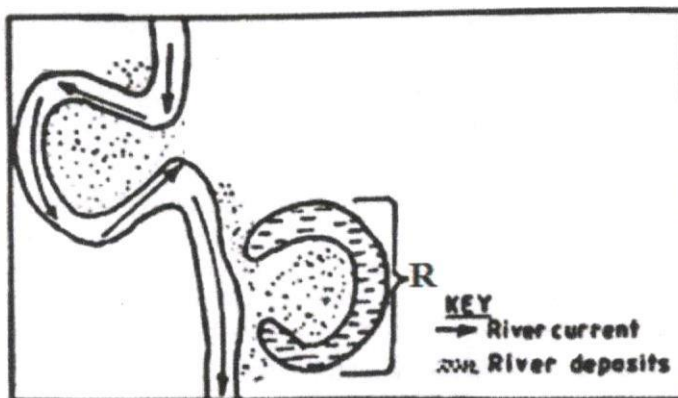

- (a) Identify the stage of development of the section of the river. (1 mark)
(b) Apart from feature marked R, give **two** other features formed at this stage. (2 marks)

5. (a) Draw a well labeled diagram of the hydrological cycle. (5 marks)
(b) State **two** ways in which underground water may reach the surface of the earth. (2 marks)

SECTION B

Answer Question 6 and Any Other Two Questions from this Section.

6. Study the map of Nyeri 1:50,000 (sheet 120/4) provided and answer the following questions.
 - a) (i) Give the longitudinal extent of the area covered by the map. (2 marks)
(ii) Give the six figure grid reference of the trigonometric station at Nyeri Hill Forest. (2 marks)
(iii) Calculate the area of Nyeri Forest. Give your answer in square kilometers. (2 marks)

- b) (i) What is the bearing of The Ark Lodge from trigonometric station 120 UT 16. *(2 marks)*
(ii) Identify **three** man-made features in grid square 7263. *(3 marks)*
(iii) Give **three** drainage features found in the area covered by the map. *(3 marks)*
- c) Describe the relief of the area covered by the map. *(5 marks)*
- d) Citing evidence from the map, identify three social services offered in Nyeri Township. *(6 marks)*
7. (a) (i) State **two** causes of faulting. *(2 marks)*
(ii) Differentiate between a normal fault and a reverse fault. *(4 marks)*
- (b) (i) Apart from Rift Valley, give three other relief features formed due to faulting. *(3 marks)*
(ii) With the aid of diagrams, describe how compressional forces can lead to formation of a rift valley. *(8 marks)*
- (c) Explain **four** effects of faulting on drainage. *(8 marks)*
8. (a) Give **three** examples of chemically formed sedimentary rocks. *(3 marks)*
(b) (i) State **three** conditions necessary for the growth of coral. *(3 marks)*
(ii) Describe how coral rocks are formed. *(4 marks)*
- (c) Explain **four** ways in which rocks contribute to the economy of Kenya. *(8 marks)*
- (d) Some students are planning to carry out a field study on rock weathering around their school.
- (i) List **three** secondary sources of information they are likely to use as they prepare for the field study. *(3 marks)*
- (ii) Apart from using secondary sources, state **four** other ways in which the students would prepare themselves for the field study. *(4 marks)*
9. (a) Describe plucking as a process in glacial erosion. *(4 marks)*
(b) Explain three conditions that lead to glacial deposition. *(6 marks)*

- (c) The diagram below shows features resulting from glacial deposition in a lowland area.

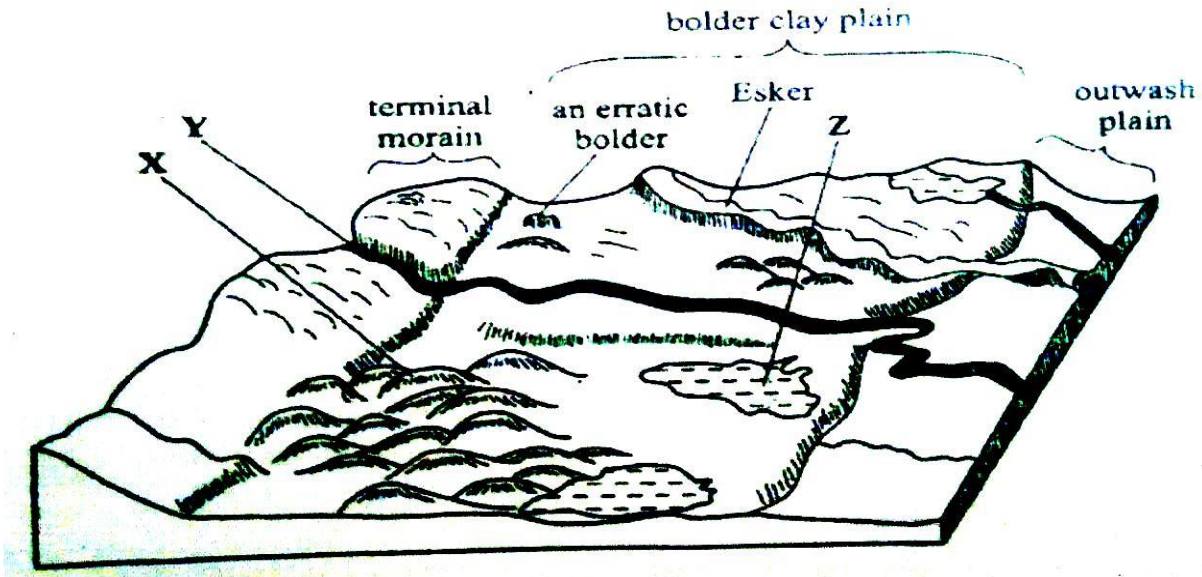

- (i) Name the features marked X, Y and Z. (3 marks)
- (ii) Describe how terminal moraine is formed. (4 marks)
- (d) Explain four positive effects of glaciation in lowland area. (8 marks)
10. (a) (i) Define the term earthquake. (2 marks)
- (ii) List three major earthquake zones of the world. (3 marks)
- (b) Differentiate between seismic focus and epicenter. (2 marks)
- (c) Explain four natural causes of earthquake. (8 marks)
- (d) Explain five effects of earthquake in built up areas. (10 marks)

KCSE 2023 TOP PREDICTION MASTER CYCLE 8

GEOGRAPHY
(QUESTION PAPER I)

FORM FOUR

TIME: 2 3/4 HOURS

Name: Adm No:

School: Class:

Signature: Date:

Instructions to candidates

- (a) Write your name, admission number and class in the spaces provided above.
- (b) This paper has **two** sections: **A** and **B**
- (c) Answer **all** the questions in section **A**
- (d) Answer **question 6** and any other **two** questions from section **B**
- (e) All answers must be written in the spaces provided after Question 10.
- (f) This paper consists of **14** printed pages.
- (g) Candidates should check the question paper to ascertain that all the pages are printed as indicated and that no questions are missing.

For Examiner's Use Only

Section	Questions	Candidate's Score	Maximum Score
A	1 – 5		25
B	6		25
			25
			25
	Total Score		100

SECTION A

Answer ALL questions in this section.

(a) Name the first **two** planets of the solar system.

(2 marks)

.....
.....
.....
.....

(b) State **three** effects of the rotation of the earth on its axis.

.....
.....
.....
.....

(3 marks)

The diagram below shows the angles of the sun's rays at different altitudes when the sun is overhead at the equator. Use it to answer question (a) and (b).

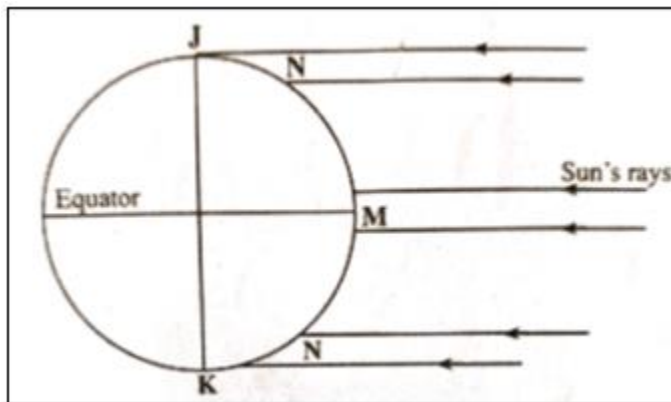

Name the parts of earth's surface marked **J** and **K**.

(2 marks)

.....
.....
.....
.....

Give **two** reasons why the intensity of insolation is higher at **M** than at **N**. (2 marks)

.....
.....
.....
.....

(a) Identify the temperate grasslands found in the following countries.

(i) Canada (1 mark)

.....
.....
.....
.....

(ii) Russia (1 mark)

.....
.....
.....
.....

(iii) Australia (1 mark)

.....
.....
.....
.....

(b) Give **two** reasons why the Tundra region has scanty vegetation. (2 marks)

.....
.....
.....
.....

(a) Identify **two** sources of water found in a lake. (2 marks)

.....
.....
.....
.....

(b) Give **three** ways through which lakes are formed. (3 marks)

.....
.....
.....
.....

(a) Give **three** factors that determine soil leaching. (3 marks)

.....
.....
.....
.....

(a) (b) State **three** ways in which mulching helps in soil conservation. (3 marks)

.....
.....
.....
.....

SECTION B

Answer question 6 and any other two questions from this section.

Study the map of Nyeri 1:50,000 (sheet 120/4) provided and answer the following questions.

- (a) (i) Identify **two** map sheets to the eastern part of Nyeri. (2 marks)
(ii) Name **two** administrative units found in Nyeri. (2 marks)
(iii) Calculate the magnetic declination of the area covered by the map as at 1978. (3 marks)
- (b) (i) Give **three** types of natural vegetation found in the area covered by the map. (3 marks)
(ii) Measure the length of the road D 432 in the southern part from Unjiru junction to Kangaita market. Give your answer in kilometers. (2 marks)
- (c) Using a vertical scale of 1cm to represent 50 metres;
(i) Draw a cross section from grid reference 680630 to 730650. (4 marks)
(ii) On the cross section, mark and name the following;
 - Hill (1 mark)
 - River (1 mark)
 - Road D 449 (1 mark)
- (d) Citing evidence from the map, identify **three** economic activities in the area covered by the map. (6 marks)
1. (a) (i) Define the term folding. (2 marks)
(ii) Name **two** fold mountains that were formed during Alpine orogeny. (2 marks)
(b) (i) Apart from fold mountains, give **three** other features resulting from folding. (3 marks)
(ii) With the aid of a diagram, describe the formation of an overthrust fold. (6 marks)
(a) Explain **three** positive effects of fold mountains on human activities. (6 marks)
(b) Members of your class are planning to carry out a field study on an area that has undergone folding process.
(i) Give **three** ways you would prepare for the study. (3 marks)
(ii) State **three** advantages of studying landforms through field work. (3 marks)
2. (a) (i) What is weathering? (2 marks)
(ii) Apart from plants, give **three** other factors that influence the rate of weathering. (3 marks)
(iii) Explain **two** ways in which plants cause weathering. (4 marks)

(b) Describe the following processes of weathering:

(i) Block disintegration (4 marks)

(ii) Carbonation (4 marks)

(c) Explain **four** effects of mass wasting on the environment. (8 marks)

3. (a) (i) Apart from surface run off, give **two** other processes in the hydrological cycle. (2 marks)

(ii) State **three** factors that determine the amount of surface run off. (3 marks)

(b) Explain **three** factors that influence the transportation of materials by a river. (6 marks)

(c) (i) What is river rejuvenation? (2 marks)

(ii) Explain **three** conditions that lead to rejuvenation of a river. (6 marks)

(d) Explain **three** negative effects of rivers to the human environment. (6 marks)

4. (a) (i) What is an ice sheet? (2 marks)

(ii) Explain **three** factors that influence the movement of ice from the point of accumulation. (6 marks)

(b) Describe how an arête is formed. (6 marks)

(c) The diagram below shows features resulting from glacial deposition on a lowland area.

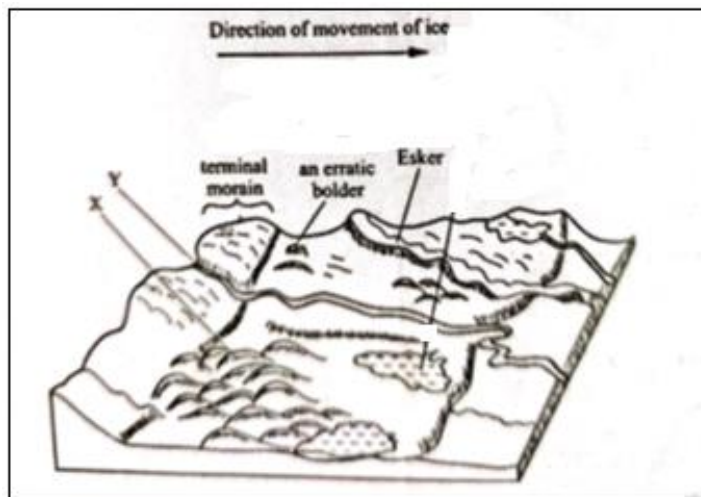

(i) Name the features marked **X** and **Y**. (2 marks)

(ii) Describe how terminal moraine is formed. (3 marks)

(d) Explain **three** positive effects of glaciation in lowland areas. (6 marks)

A series of 27 horizontal dotted lines for writing.



.....

.....

.....

.....

.....

.....

.....

.....

.....

.....

.....

.....

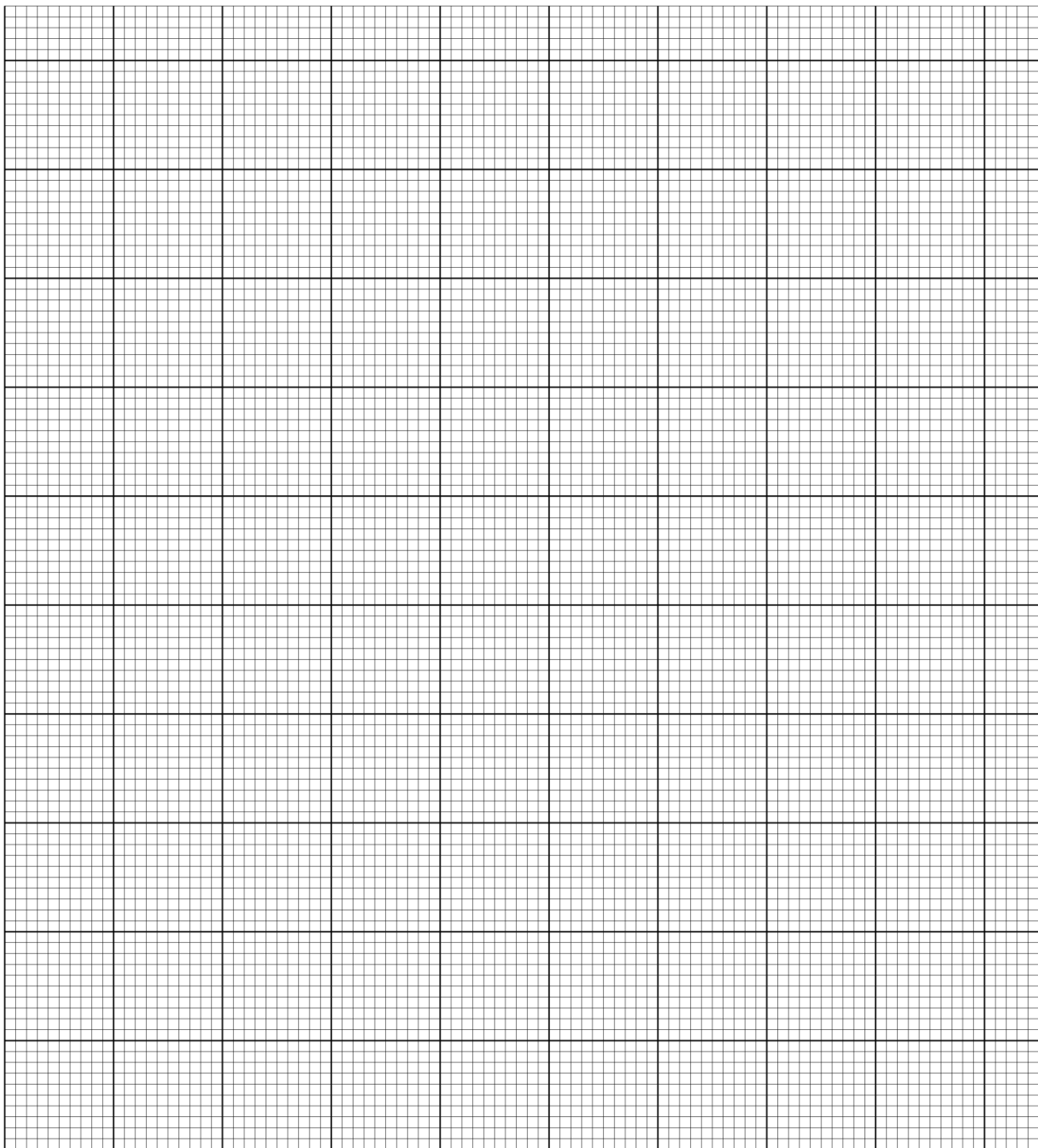

NAME..... ADM NO.....
 SCHOOL..... CLASS.....
 SIGNATURE..... DATE.....

GEOGRAPHY

FORM 4 PAPER 1

TIME 2¾ HOURS

KCSE TOP PREDICTION MASTER CYCLE 9

Instructions to candidates

- (a) Write your name, admission number and class in the spaces provided above.
- (b) This paper has **two** sections: **A** and **B**
- (c) Answer **all** the questions in section **A**
- (d) Answer **question 6** and any other **two** questions from section **B**
- (e) **This paper consists of 14 printed pages.**
- (f) **Candidates should check the question paper to ascertain that all the pages are printed as indicated and that no questions are missing.**

For Examiner’s Use Only

Section	Questions	Maximum Score	Candidate’s Score
A	1 – 5	25	
B	6	25	
		25	
		25	
	Total Score	100	

SECTION A

Answer all questions in this section

1. (a) Define the term equinox. *(2 marks)*
(b) If the local time at 75°W is 8.00 a.m., what is the local at the longitude 35°E ? *(3 marks)*

2. (a) Give **two** examples of non-metallic minerals. *(2 marks)*
(b) State **three** ways through which sedimentary rocks are formed. *(3 marks)*

3. (a) What is natural vegetation? *(2 marks)*
(b) State **three** characteristics of Mediterranean type of vegetation. *(3 marks)*

4. The diagram below shows a barchan. Use it to answer question (a).

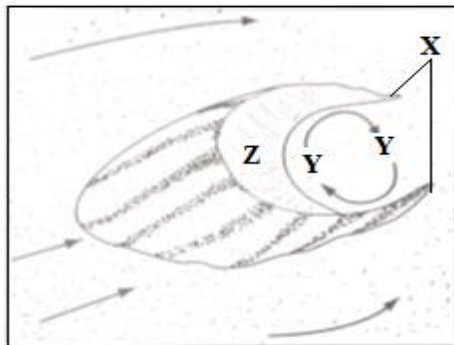

- (a) Name
 - (i) the feature marked **X**. *(1 mark)*
 - (ii) the air current marked **Y**. *(1 mark)*
 - (iii) the slope marked **Z**. *(1 mark)*

(b) Give **two** ways in which wind transport its load in deserts. (2 marks)

5. (a) Differentiate between a catchment area and a watershed. (2 marks)

(b) Give **three** features that result from river rejuvenation. (3 marks)

SECTION B

*Answer **question 6** and any other **two** questions from this section*

6. Study the map of KIJABE 1:50,000 (134/3) provided to answer the following questions.

(a) (i) What is the approximate height of Kijabe hill? (1 mark)

(ii) Give the six grid reference of the school at Mai Mahiu in the southern area. (2 marks)

(iii) Calculate the area covered by the thicket to the west of the rail way line. (2 marks)

(b) (i) What is the approximate location of Kijabe Railway Station in terms of latitude and longitude? (2 marks)

(ii) Identify **three** methods used to represent relief on the area covered by the map. (3 marks)

(c) Draw a rectangle measuring 10cm by 5cm to represent the area enclosed by easting 30 and 40 and Northing 95 and 00. (1 mark)

On it mark and name the following features:

• Railway (1 mark)

• All weather road bound surface (1 mark)

• Forest (1 mark)

• Murrum pit (1 mark)

(d) Citing evidence from the map, identify **two** economic functions of Kijabe centre. (4 marks)

(e) Explain **three** factors influencing the distribution of vegetation in the area covered by the map. (6 marks)

7. (a) (i) What is plate tectonics? *(2 marks)*
- (ii) Explain **three** evidences supporting the continental drift theory. *(6 marks)*
- (b) (i) Apart from fold mountains, give **three** other features resulting from folding. *(3 marks)*
- (ii) With the aid of well labeled diagrams, describe how movement of tectonic plates may lead to formation of fold mountains. *(8 marks)*
- (c) Explain **three** positive significance of fold mountains to human activities. *(6 marks)*

8. (a) (i) Define the term climate. *(2 marks)*
- (ii) Explain how the following factors influence the climate of an area.
- latitude *(2 marks)*
 - distance from the sea *(2 marks)*

(b) The table below shows temperature readings at a weather station.

Day	MON.	TUE.	WED.	THUR.	FRI.	SAT.	SUN
Max (°C)	26	25	26	24	27	27	24
Min. (°C)	15	17	17	13	19	18	17

Calculate;

- (i) the diurnal temperature range for Monday. *(2 marks)*

(ii) the mean daily temperature for Friday.

(2 marks)

(c) Study the climate map of Africa below and answer the questions that follow.

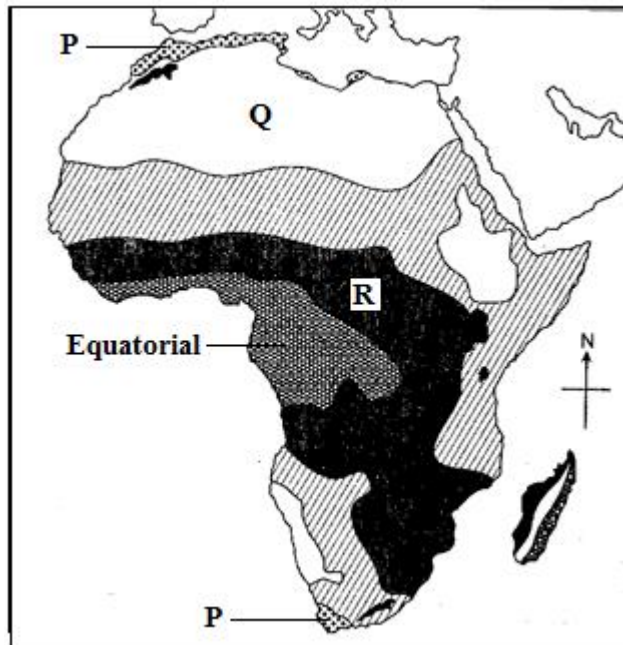

(i) Name the climatic regions marked P, Q and R.

(3 marks)

(ii) Describe the characteristics of equatorial climate.

(6 marks)

(d) Explain **three** ways in which vegetation has adapted to the climatic conditions in the region Q.

(6 marks)

9. (a) (i) What is an artesian basin?

(2 marks)

(ii) Explain **three** factors which influence the formation of features in limestone areas. (6 marks)

(b) (i) Apart from stalagmites, name **two** other underground features in limestone areas. (2 marks)

(ii) With the aid of a diagram, describe how a stalagmite is formed.

(8 marks)

(c) You are supposed to carry out a field study on limestone region.

(i) Give **two** reasons why you would need a map of the area of study. (2 marks)

(ii) State **two** ways you would prepare for the study. (2 marks)

(iii) Give **three** reasons why you are likely to find few settlements in the study area. (3 marks)

10. (a) (i) Define the term glacier. (2 marks)

(ii) Give **two** processes of glacial erosion. (2 marks)

(b) Explain **three** conditions that lead to glacial deposition. (6 marks)

(c) The diagram below shows features resulting from glacial deposition in lowlands.

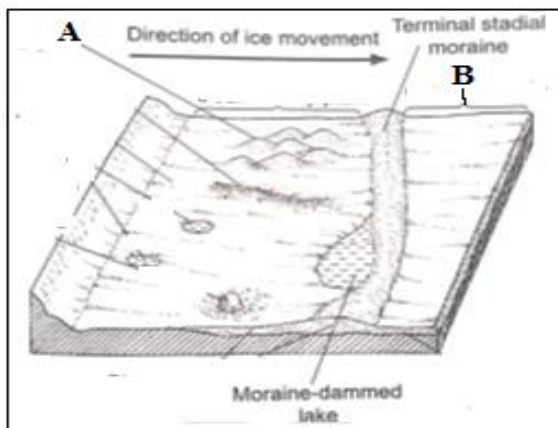

(i) Identify the features labeled **A** and **B**. (2 marks)

(ii) Describe how a terminal moraine is formed. (3 marks)

(d) Explain **five** positive significance of glaciation in lowland areas. (10 marks)



.....

.....

.....

.....

.....

.....

.....

.....

.....

.....

.....

.....

.....

.....

.....

.....

.....

.....

.....

.....

.....

.....

.....

.....

.....

.....

.....

.....

.....

.....

.....

.....

.....

.....

.....

.....

.....

.....

.....

.....

.....

.....

.....

.....

.....

.....

.....

.....

.....

.....

.....

.....

.....

.....

.....

.....

.....

.....

.....

.....

.....

.....

.....

.....

.....

.....

.....

.....

.....

.....

.....

.....

.....

.....

.....

.....

.....

.....

.....

Dotted lines for writing content.

.....

.....

.....

.....

.....

.....

.....

.....

.....

.....

.....

.....

.....

.....

.....

.....

.....

.....

.....

.....

.....

.....

.....

.....

.....

.....

.....

.....

.....

.....

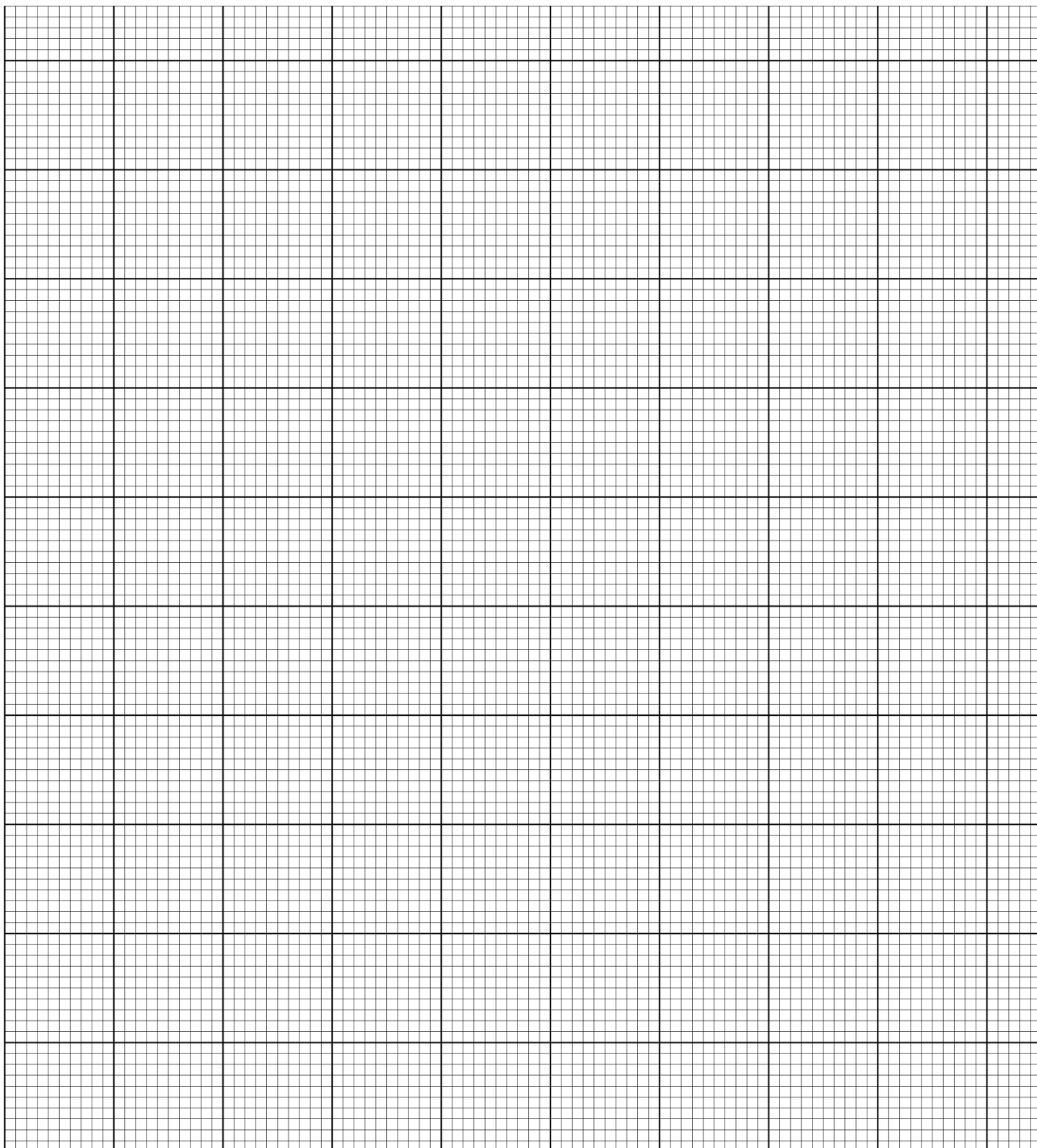

NAME:ADM NO.:CLASS

SIGNATURE:DATE:

SCHOOL

312/ 1
GEOGRAPHY
PAPER 1
2 ³/₄ Hours

KCSE TOP PREDICTION MASTER CYCLE 10

INSTRUCTIONS:

- This paper consists of **two** sections A and B.*
- Answer all the questions in section A.*
- Answer question **six** and any other **two** questions from section B*
- This paper consists of four printed pages. Candidates should check the question paper to ascertain that all the pages are printed and that no questions are missing.*

FOR EXAMINERS USE ONLY

SECTION	Questions	Maximum score	Candidate's score
A	1-5	25	
B	6	25	
		25	
		25	
TOTAL SCORE			

SECTION A

Answer all questions in section A

1. (a) What is the relationship between geography and mathematics. (2mks)
(b) State **two** reasons why it is important to study geography. (2mks)
2. (a) What is a line of longitude? (2 marks)
(b) What is the local time of Alexandria 30°E when the local time at Malindi 40°E is 12.00 noon? (2 marks)
3. (a) State **three** causes of earth movement (3 marks)
(b) Name **two** main earthquake zones in the world (2 marks)
4. (a) Name **three** features found on emerged highland coast (3 marks)
(b) State **three** conditions necessary for the formation of a spit (3 marks)
5. (a) Highlight any **three** factors that necessitate the occurrence of an artesian basin (3 marks)
(b) Apart from lakes, rivers and sea, name any other **two** sources of underground water (3 marks)

SECTION B

Answer question 6 and any other two questions from this section.

6. Study the map of NYERI 1:50,000(sheet 120/4) provided and answer the following questions.
 - (a) i) What is the title of the map extract (1 mk)
ii) Name two districts covered by the map extract (2 mks)
iii) Give three physical features found in grid square 5085 (3 mks)
 - (b) (i) Give the longitudinal extent of the area covered by the map. (2mks)
(ii) What is the magnetic declination shown on the map? (2mks)
 - (c) (i) What is the altitude at the peak of Nyeri hill? (2mks)
(ii) Give three methods used to represent relief on the map. (3mks)
(iii) Measure the length of the dry weather road (Naivasha road) from Tusha welfare centre junction school to the edge of the map towards North Kinangop and Naivasha in kilometres (2mks)
 - (d) Describe the drainage of the area covered by the map. (5mks)

(e) Citing evidence from the map, identify three social services offered in Mweiga municipality
(3mks)

7.a)i) Name three types of faults (3mks)

ii) Apart from compressional forces, explain two other processes that may cause faulting
(4mks)

b) i) With the aid of a well labeled diagram, describe how a rift valley is formed by compressional forces (6mks)

ii) Explain three ways in which faulting may influence drainage system (6mks)

c) Explain three ways in which faulting is of significance to human activities (6mks)

8. a) i) What is micro-climate? (2mks)

ii) State two negative effect of desertification (2mks)

b) Draw a sketch map Africa and indicate the ocean currents.

i. Benguela, Guinea, Agulhas/ Mozambique (4mks)

ii. State two effects of Benguela Current on the adjacent coastlands (2mks)

c) Describe the characteristics of the Equatorial type of climate (8mks)

d) Explain how the following factors influence climate:

i. Altitude (4mks)

ii. Distance from the sea (3mks)

9.a) (i) Differentiate between a watershed and a drainage basin (2 marks)

(ii) State three processes of river erosion (3 marks)

b)(i) Give three ways in which river transport its load (3 marks)

(ii) State four factors which influence river deposition (4 marks)

c) Give three characteristics of a river in its middle stage (3 marks)

d)(i) Name two features produced by river rejuvenation. (2 marks)

(ii) Describe how river capture occur. (4 marks)

(iii) Explain two positive effects of rivers to the human *environment* (4 marks)

10. a) (i) What is an ice sheet? (2 marks)

(ii) Give two reasons why there are no ice sheets in Kenya (2 marks)

(iii) Explain three factors that influence the movement of ice from the place of accumulation

(6 marks)

b) Describe how an arête is formed (4 marks)

c) The diagram below shows types of moraines in a valley glacier

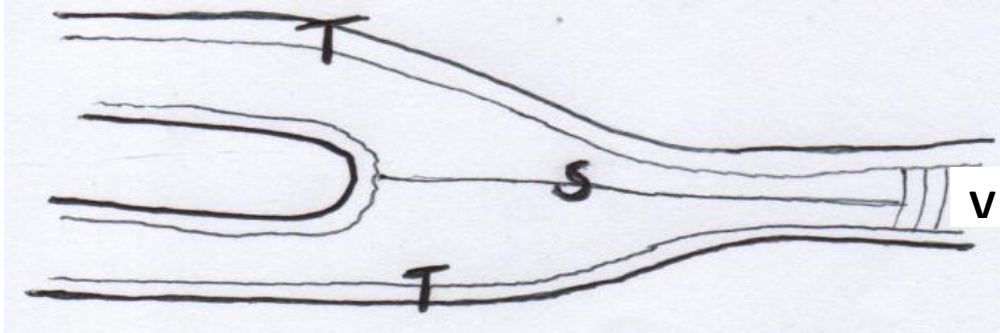

(i) Name the type of moraines marked S, T and V

(3 marks)

(ii) Explain four positive effects of glaciations in lowland areas

(8 marks)