

NAME..... INDEX NUMBER.....

ADM NO.....CLS.....

121/2
MATHEMATICS
PAPER 2
TIME: 2 ½ HOURS

KCSE 2023 TOP PREDICTION MASTER CYCLE 3

KENYA CERTIFICATE OF SECONDARY EDUCATION (K.C.S.E)

INSTRUCTIONS TO CANDIDATES

- Write your name and index number in the spaces provided above.
- This paper consists of **TWO** sections: **Section I** and **Section II**.
- Answer **ALL** the questions in **Section I** only **five** questions from Section II.
- Show all the steps in your calculations, giving your answers at each stage in the spaces provided below each question.

For Examiner's Use Only

Section I

1	2	3	4	5	6	7	8	9	10	11	12	13	14	15	16	Total

Section II

17	18	19	20	21	22	23	24	Total

SECTION 1 (50 MARKS)

1. Evaluate using squares, cubes and reciprocal tables (4 marks)

$$\left[\frac{1}{\sqrt[3]{27.56}} + \frac{3}{(0.071)^2} \right]^{-2}$$

2. Make x the subject in $\frac{x^4 - 4}{x^2 - 2} = K$ (3 marks)

3. Ali deposited Ksh.100,000 in a financial institution that paid simple interest at the rate of 12.5% p.a. Mohamed deposited the same amount of money as Ali in another financial institution that paid compound interest. After 4 years, they had equal amounts of money. Determine the compound interest rate per annum to 1 decimal place. (3 marks)

4. Simplify

(3 marks)

$$\left(\frac{a^3 - ab^2}{a^4 - b^4} \right)^{-1}$$

5. Expand $(1 - 2x)^4$, hence find the value of $(1.02)^4$ correct to 3 significant figures.
(3 marks)

6. If $\sin x = 2b$ and $\cos x = 2b\sqrt{3}$, find the value of b (3 marks)

7. Find the relative error in $\frac{a + b}{c - d}$ given that $a = 77ml$, $b = 23ml$,
 $c = 36ml$, and $d = 16ml$. (3 marks)

8. Without using a calculator or mathematical tables, express
 $\frac{\sqrt{3}}{1 - \cos 30^\circ}$ in surd form and simplify. (3 marks)

9. The equation $3x^2 - 8px + 12 = 0$ has real roots.
Find the value of P. (2 marks)

10. A construction company employs 200 artisans and craftsmen in the ratio 1:3 every week. An artisan is paid $2\frac{1}{2}$ times as much as a craftsman. At the end of 3 weeks the company paid ksh 1485000 to those employees. Find how much each artisan and each craftsman is paid. (a working week has six days)
(3 marks)

11. A dam containing 4158m^3 of water is to be drained. A pump is connected to a pipe of radius 3.5cm and the machine operates for 8 hours per day. Water flows through the pipe at the rate of 1.5m per second. Find the number of days it takes to drain the dam. (4 marks)

12. Two brands of coffee Arabica and Robusta costs sh.4,700 and sh.4,200 per kilogram respectively. They are mixed to produce a blend that costs shs.4,600 per kilogram. Find the ratio of the mixture. (3 marks)

13. Under a transformation represented by a matrix $\begin{pmatrix} 5X & 2 \\ -3 & X \end{pmatrix}$, a triangle of area 10cm^2 is mapped onto a triangle whose area is 110cm^2 . Find x (3 marks)

14. Find the distance between the centre O of a circle whose equation is $2x^2 + 2y^2 + 6x + 10y + 7 = 0$ and a point $B(-4,1)$. (3 marks)

15. Solve for x in the equation:
 $(\log_2 x)^2 + \log_2 8 = \log_2 x^4$ (4 marks)

16. The figure below shows a circle inscribed in an isosceles triangle ABC . If Q , P and R are the points of contact between the triangle and the circle, O is the centre of the circle, $BO = 19.5\text{cm}$ and $BQ = 18\text{cm}$. Find the radius of the circle and hence the length of the minor arc PQ . (3 marks)

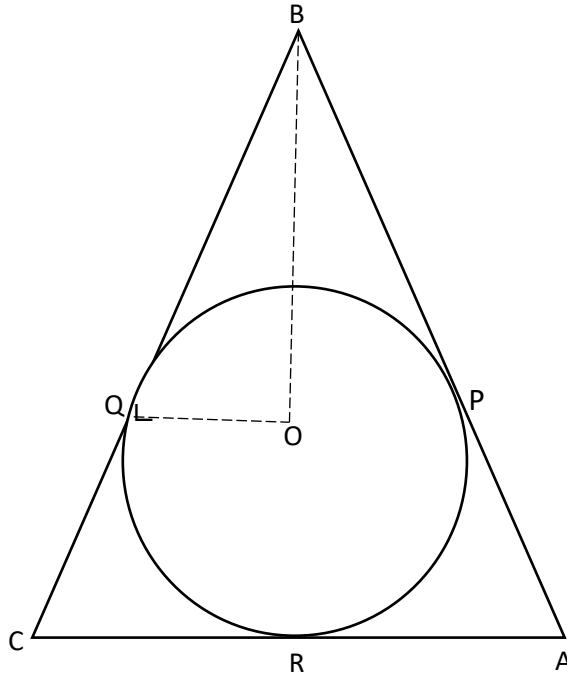

SECTION II (50 MARKS)

ANSWER ONLY FIVE QUESTIONS

17.(a) Mr. Mackey pays a tax of Kshs.5,800 per month according to the income tax table given below. He is married and entitled to a family relief of K€ 420p.a.

Taxable income	Rate (Ksh per K€)
(K€ p.a.)	
1 – 9,600	2
9,600 – 19,200	3
19,201 – 29,800	5
29,801 - 38,400	7
38,401 - 47,200	9
Over 47,200	10

Calculate Mackey's gross annual salary in K€

(6marks)

(b) The difference between compound interest and simple interest on Kshs.P over a duration of 36 months at the rate of 15% p.a. is Kshs.52,477.50. Calculate the value of P.
(4 marks)

18. (a) Complete the table below for $y = x^3 + 4x^2 - 5x - 5$ (2 marks)

X	-5	-4	-3	-2	-1	0	1	2
y			19			-5		

(b) On the grid provided, draw the graph of $y = x^3 + 4x^2 - 5x - 5$ for $-5 \leq x \leq 2$ (3 marks)

(c) i) Use the graph to solve the equation $x^3 + 4x^2 - 5x - 5 = 0$ (2 marks)

ii) By drawing a suitable straight line on the graph, solve the equation $x^3 + 4x^2 - 5x - 5 = -4x - 1$ (3 marks)

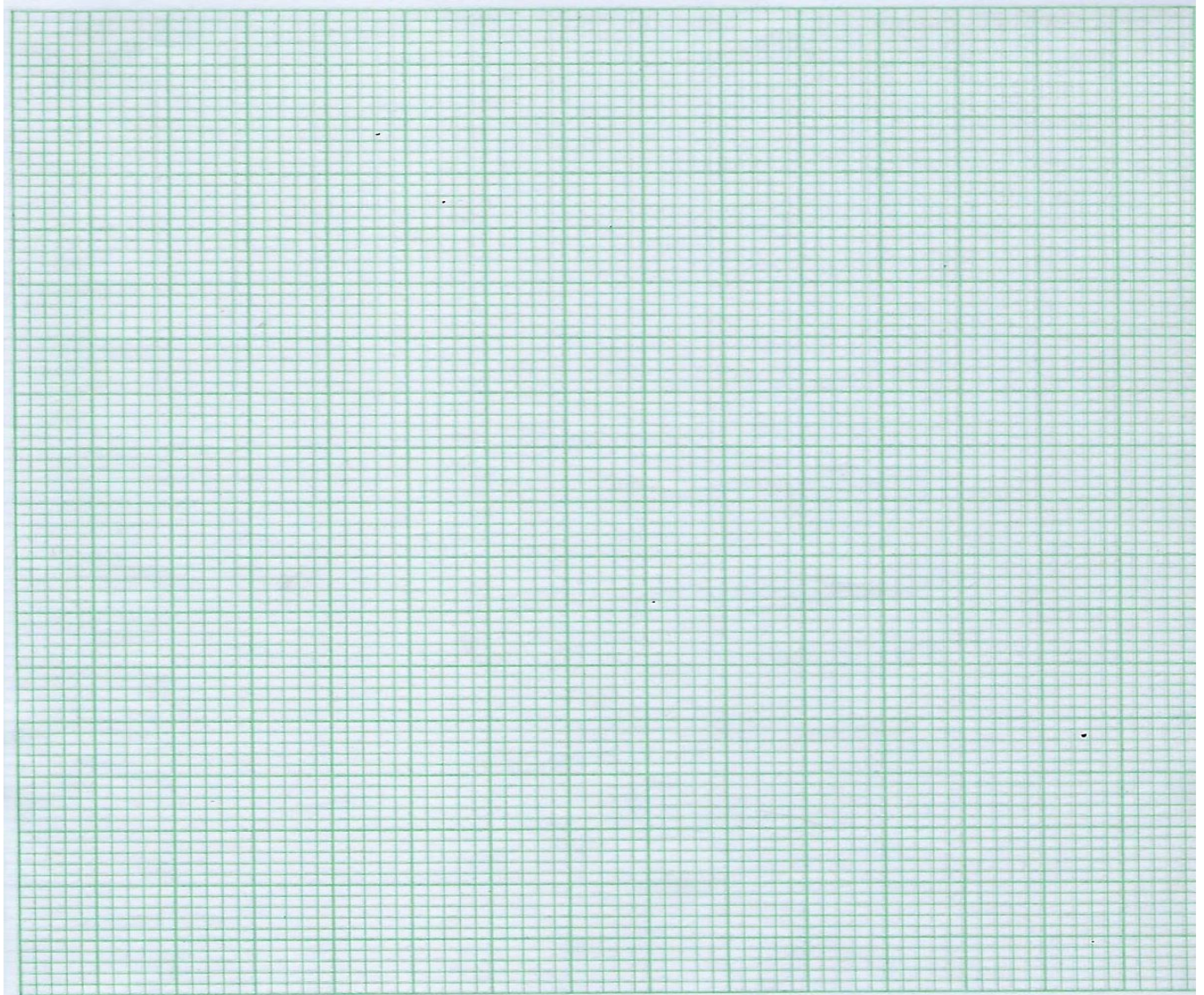

19. OPQ is a triangle in which $OP = p$ and $OQ = q$. x is a point on OP such that $OP:XP = 5:2$ and y is another point on PQ such that $PY:YQ = 1:2$. Lines OY and XQ intersect at T .

(a) Express the following vectors in terms of p and q

(i) PQ (1 mark)

(ii) OY (1 mark)

(iii) OX (1 mark)

(b) If $OT = kOY$ and $QT = hQX$ express OT in two different ways. Hence or otherwise find the values of h and k . (6 marks)

(c) Determine the ratio $OT:TY$ (1 mark)

20. If $(x - 1\frac{1}{8})$, x and $(x + \frac{3}{2})$ are the first three consecutive terms of a geometric progression;

(a) Determine the values of x and the common ratio. (4 marks)

(b) Calculate the sum of the first 6 terms of this progression. (3 marks)

(c) Another sequence has the terms
-13, -16, -19,-310.

Find the sum of this sequence.

(3 marks)

21. The figure below shows a belt passing round two pulleys of centres A and B. The radius of the pulleys is 4cm and 6cm respectively and the distance between the centres is 25cm.

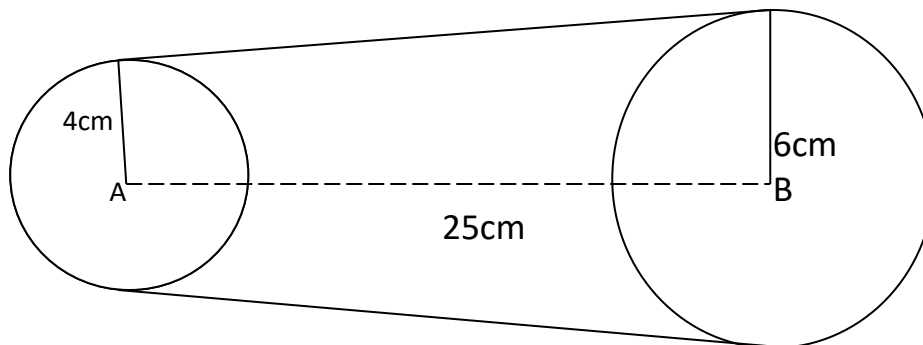

Calculate the length of the belt used for the pulley system. (10 marks)

22. The points P(2,1), Q(4,1) R(4,3) and S(3, 3) are coordinates of a quadrilateral.
- (a) Plot the quadrilateral PQRS on the grid provided. (1 mark)
 - (b) Find the coordinates of $P^1Q^1R^1S^1$ the image of PQRS under the transformation represented by the matrix $M = \begin{pmatrix} 1 & 1 \\ 2 & 0 \end{pmatrix}$ (2 marks)
 - (c) Draw and label $P^1Q^1R^1S^1$ on the same grid.
 - (d) Find the coordinates of $P^{11}Q^{11}R^{11}S^{11}$ on the image of $P^1Q^1R^1S^1$ under the transformation represented by the matrix $N = \begin{pmatrix} -2 & 1 \\ 0 & 1 \end{pmatrix}$ (2 marks)
 - (e) Draw and label $P^{11}Q^{11}R^{11}S^{11}$ on the same grid. (1 mark)
 - (f) Determine the matrix that maps PQRS directly onto $P^{11}Q^{11}R^{11}S^{11}$. (3 marks)

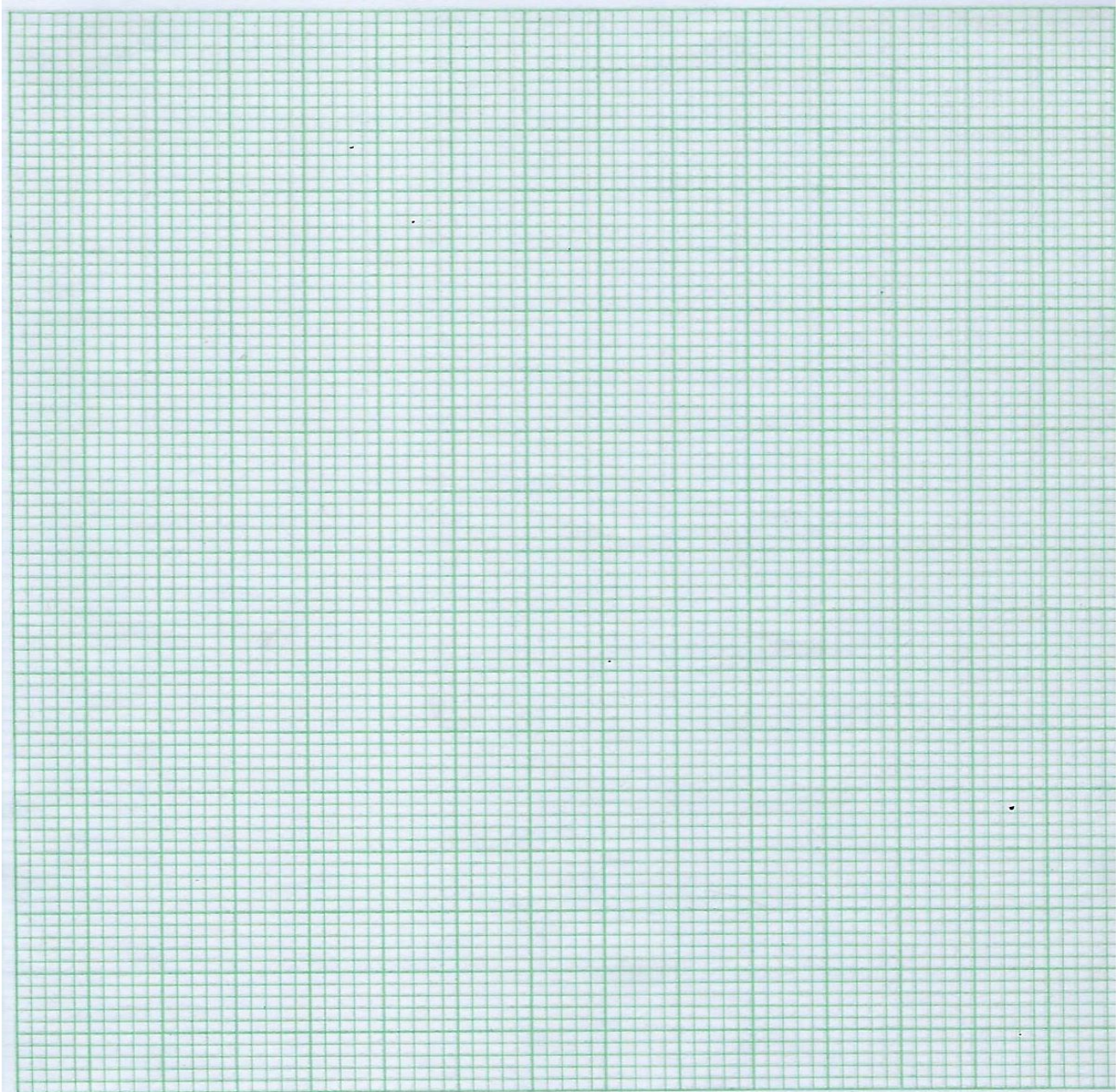

23. The table below shows the ages of people in years who attended a wedding ceremony.

Age in years	10-19	20-29	30-39	40-49	50-59	60-69	70-79
Frequency	2	4	4	8	6	3	2

(a) State the modal class

(1 mark)

(b) Using an assumed mean of 44.5 calculate

(i) The mean age (3 marks)

(ii) The standard deviation (3 marks)

(iii) The median age (3 marks)

24. A supermarket is stocked with plates which come from two suppliers A and B. They are bought in the ratio 3:5 respectively, 10% of plates from A are defective and 6% of the plates from B are defective.

(a) A plate is chosen by a buyer at random.

Find the probability that

i) It is from A (2 marks)

ii) It is from B and it is defective (2 marks)

iii) It is defective (2 marks)

(b) Two plates are chosen at random. Find the probability that;

i) Both are defective (2 marks)

ii) At least one is defective (2 marks)