

KPSEA 2023 REGIONAL MOCKS

MATHEMATICS

GRADE 6

**THE PDF COMPRISES A COMPILATION OF TOP 4
JOINT NATIONAL MOCKS ACROSS THE 47
COUNTIES FOR THE KPSEA CLASS OF 2023**

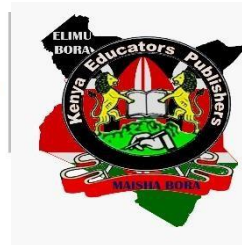

FOR MARKING SCHEMES:

CONTACT:

MR MACHUKI – 0724333200

OR

ORDER ONLINE AT:

www.kenyaeducators.co.ke

KENYA EDUCATORS CONSULTANCY

TABLE OF CONTENTS:

| | |
|----|--|
| 1. | THE NAIROBI & CENTRAL REGIONS KCSE JOINT NATIONAL MOCK 2023 |
| 2. | THE NYANZA & WESTERN REGIONS KCSE JOINT NATIONAL MOCKS 2023 |
| 3. | THE COASTAL & EASTERN REGIONS KCSE JOINT NATIONAL MOCK 2023 |
| 4. | THE RIFT VALLEY & NORTH EASTERN REGIONS KCSE JOINT NATIONAL MOCK 2023 |

CONFIDENTIAL!!!

SUCCESS TO ALL KPSEA 2023 CANDIDATES!!!

**THE NAIROBI & CENTRAL REGIONS KPSEA JOINT
NATIONAL MOCK 2023**



MATHEMATICS

Time: 1 Hour 40 Minutes



READ THESE INSTRUCTIONS CAREFULLY.

1. You have been given this question booklet and a separate answer sheet. The question bookier contains 30 questions.
2. Do any necessary rough work in this booklet.
3. When you have chosen your answer, mark it on the **ANSWER SHET**, not in the question paper.

HOW TO USE THE ANSWER SHEET.

4. Use an ordinary pencil only.
5. Make sure that you have written on the answer sheet.

YOUR INDEX NUMBER

YOUR NAME

NAME OF YOUR SCHOOL

6. By drawing a **dark line** inside the correct numbered boxes mark your full index number (i.e. school code Number and the three -figure candidate's Number) in the grid near the top of the answer sheet.
7. Do not make any marks outside the boxes.
8. Keep your answer sheet as clean as possible and Do not fold it."
9. For each question 1-30 four answers are given. The answers are lettered A, B, C, D. In each case Only One of the four answers is correct. Chose the correct answer.
10. On the answer sheet show the correct answer by drawing a dark line inside the box in which the letter you have chosen is written.
11. Your dark line Must be within the box. Make your line as dark as possible.
12. For each question **Only One box** is to be marked in each set of four boxes.

Candidates should check the question papers to ensure that all questions are printed.

KENYA EDUCATORS CONSULTANCY

1. Bogita planted seventy nine thousand, four hundred and three tree seedlings in a certain rainy season. What is the number of the seedlings in symbols?
- A. 7904003
B. 709403
C. 794003
D. 79403
2. There were 37928 grade six learners in Amani County. What is the total value of digit 7 in the number?
- A. Tens
B. Seventy
C. Seven thousand
D. Thousands
3. A group of farmers delivered 83714 bags of rice in April to a factory. In May the farmers delivered 1983 less bags of rice to the factory. How many bags did the farmers deliver in May?
- A. 85697
B. 82831
C. 82731
D. 81731
4. In the year 2020, a school received 2103 books. By the end of the year 249 books got spoiled and were replaced by 286 new books. How many books were in good condition after the replacement?
- A. 2639
B. 2140
C. 1854
D. 1568
5. A fruit seller had some fruits. She wanted to put them in equal piles of 12 and 15. What was the lowest number of fruits that she could divide into equal piles of 12 and 15 without a remainder?
- A. 180
B. 60
C. 27
D. 3
6. Work out: $3045 \div 15$
- A. 2003
B. 203
C. 230
D. 23
7. During a Mathematics activity four learners had the following number of cards
- | | | | |
|-------|-------|-------|-------|
| John | Mary | Rita | Peter |
| 36224 | 58809 | 60795 | 78910 |
- They rounded off the numbers to the nearest thousands and got their answers as shown below.
- | | | | |
|-------|-------|-------|-------|
| John | Mary | Rita | Peter |
| 36200 | 58000 | 61000 | 78900 |
- Who rounded off correctly?
- A. Rita
B. John
C. Mary
D. Peter

8. Ahmed imported 13018 mobile phones in November. In December he imported 7391 more mobile phones. How many mobile phones did he import in the two months?
- A. 33427
B. 33417
C. 20409
D. 5627
9. Mwalala has a square seedbed. Each side of the seedbed is 36 metres. What is the area of the seedbed?
- A. 6m^2
B. 14m^2
C. 1156m^2
D. 1296m^2
10. Work out the value of $81 \div 9 \times 3 + 10$.
- A. 37
B. 31
C. 27
D. 18
11. Beth bought $\frac{3}{4}$ kg of meat. She cooked a $\frac{1}{2}$ kg piece of the meat for her family. She gave the remaining piece of meat to her neighbour. What fraction of the meat did she give the neighbour?
- A. $\frac{1}{4}$
B. $\frac{1}{2}$
C. $\frac{3}{8}$
D. $\frac{5}{4}$
12. What is the next number in the pattern
1, 9, 25, 49, 81, _____?
- A. 83
B. 91
C. 121
D. 169
13. A bookseller bought 184 cartons of books. Each carton contained 25 books. He sold 3712 books. How many books remained?
- A. 4600
B. 4575
C. 888
D. 998
14. Chebet had $58\frac{1}{2}$ m of wire mesh. She used $36\frac{4}{5}$ m of the wire to fence round her vegetable garden. What length of wire mesh remained?
- A. $22\frac{3}{10}$
B. $21\frac{7}{10}$
C. $18\frac{7}{10}$
D. $\frac{7}{10}$

15. The height of a building is 120.27m. The ground floor is 5.99m high. What is the height of the remaining part of the building?
- A. 126.26
B. 124.28
C. 114.38
D. 114.28

16. A grade five learner had four number cards as follows



She arranged the number cards from the largest to the smallest. Which one of the following is the correct order?

- A. 0.57, 1.057, 1.57, 1.6
B. 1.6, 1.57, 1.057, 0.57
C. 0.57, 1.6, 1.57, 1.057
D. 1.057, 1.57, 0.57, 1.6
17. Auma was asked by her class teacher to fill in the table below during a Mathematics lesson.

| | | | | | | | |
|-------------|---|---|---|---|---|---|---|
| Number | 1 | 2 | 9 | . | 0 | 8 | 4 |
| Place value | | | | | | | |

What is the place value of digit 8 in the number?

- A. Tens
B. Tenths
C. Hundredths
D. Thousandths

18. During an activity in a Mathematics lesson, learners had the following 3-D objects which are found in the environment. The teacher asked them to name the objects.

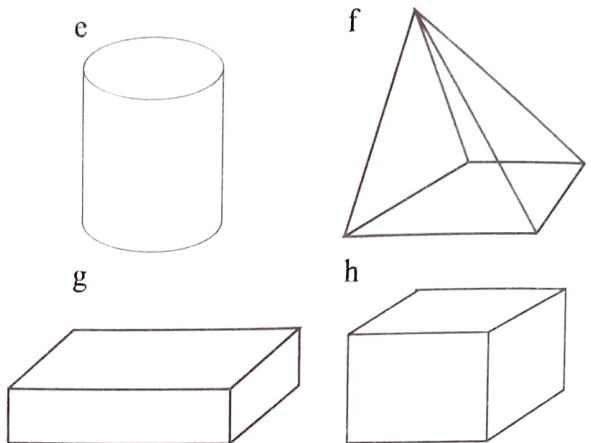

What are the correct names?

- A. (e) cylinder (f) cuboid (g) pyramid (h) cube
B. (e) cylinder (f) pyramid (g) cuboid (h) cube
C. (e) pyramid (f) cylinder (g) cube (h) cuboid
D. (e) cube (f) cuboid (g) pyramid (h) cylinder
19. Moraa used shapes to make a pattern as shown.

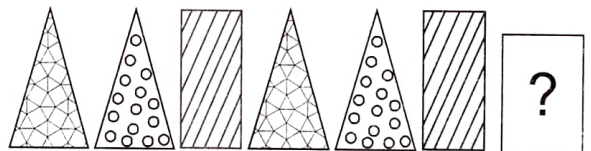

Which one of the following did she put in the box to continue with the pattern?

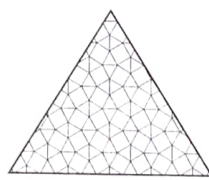
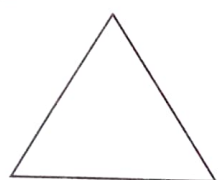
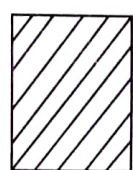
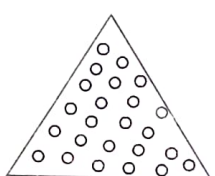
- A.  B. 
C.  D. 

20. John saw the following structure at a building construction site. He then identified the angles marked with Roman numerals.

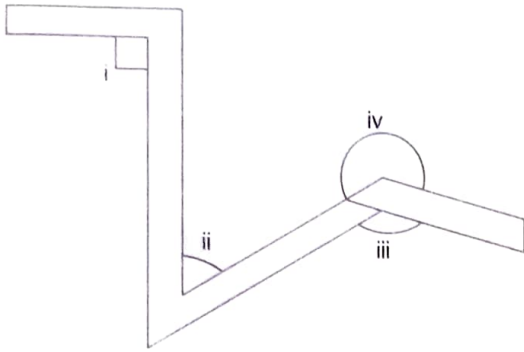

Which of the following shows the correct names of the angles?

- A. (i) Acute (ii) Obtuse (iii) Right angle (iv) Reflex
 B. (i) Obtuse, (ii) Reflex (iii) Acute (iv) Right angle
 C. (i) Right angle (ii) Acute (iii) Obtuse (iv) Reflex
 D. (i) Right angle (ii) Reflex (iii) Obtuse (iv) Acute
21. Wafula measured the angle drawn below using a protractor.

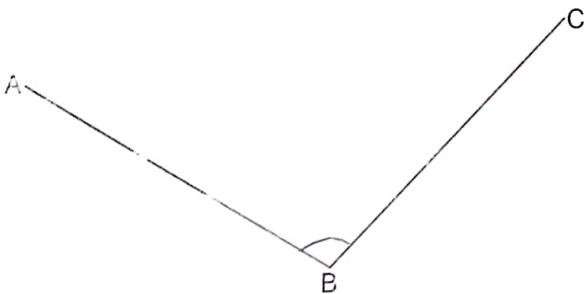

What is the correct size of the angle ABC?

- A. 115°
 B. 105°
 C. 85°
 D. 75°

22. The table below represents the number of patients who were treated of malaria in a certain hospital in five days of the week.

| Day | Mon | Tue | Wed | Thur | Fri |
|---------------|-----|-----|-----|------|-----|
| No. of people | 8 | 4 | 12 | 10 | 12 |

Mutwiri piled bottle tops to represent the number of patients treated in each day. How many more bottle tops did he pile to represent number of patients on Thursday than on Tuesday?

- A. 14
 B. 10
 C. 6
 D. 4
23. Four learners were discussing the services offered by the banks. Who among them gave incorrect answer?
- A. **Peter:** Giving loan to people
 B. **Tom:** Withdrawing money
 C. **Alice:** Keeping valuable items
 D. **Ann:** Paying taxes for people
24. The government uses taxes to provide the following services **except**
- A. to construct roads
 B. to build hospitals
 C. to build worship places
 D. to supply electricity

25. The table below shows price list in a shop.

| Item | Price |
|---------------------|--------|
| Bread | sh 55 |
| Packet of milk | sh 60 |
| 2kg packet of sugar | sh 215 |
| 1kg of cooking oil | sh 418 |
| Bottle of water | sh 50 |

Zanida bought the following items:-

A packet of sugar, 2 packets of milk, a loaf of bread and a bottle of water. How much balance did she get from sh 1000 note?

- A. Sh 798
- B. Sh 440
- C. Sh 560
- D. Sh 405

26. A farmer harvested 428kg of beans, 854kg of maize and 465kg of rice. What is the total mass that she harvested?

- A. 1747
- B. 1732
- C. 1708
- D. 1648

27. In a walking race, Odero took 23 minutes 51 seconds to finish while Kioko took 25 minutes 39 seconds. By how many minutes and seconds was Kioko ahead of Odero in the race?

- A. 1 minute 48 seconds
- B. 1 minute 46 seconds
- C. 48 seconds
- D. 1 minute 28 seconds

28. A doctor bought 12 litres of a certain medicine to treat some patients. What was the amount of medicine in millilitres?

- A. 120000
- B. 12000
- C. 1200
- D. 120

29. Mirema bought 120kg of meat during a community function. He repacked the meat into $\frac{1}{4}$ kg portions. How many portions did he get?

- A. 30
- B. 60
- C. 360
- D. 480

30. A nurse takes 3 minutes 49 seconds to vaccinate one baby. How long would she take to vaccinate 4 babies?
- A. 44 minutes 15 seconds
 B. 44 minutes 12 seconds
 C. 15 minutes 16 seconds
 D. 42 minutes 15 seconds

31. The length of a box is 9cm, the width is 7cm and the height is 14cm. What is the volume of the box?
- A. 1082cm^3
 B. 882cm^3
 C. 782cm^3
 D. 30cm^3

32. During a rainy season, Musa harvested 180 litres 40millilitres of water in seven equal buckets. How much water was in each bucket?
- A. 205L 720 ML
 B. 25L 720ML
 C. 25L 72ML
 D. 15L 720ML

33. Judy made a box shown below. She filled it with soil to plant seeds.

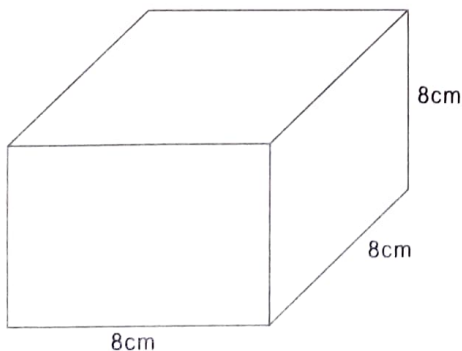

What volume of soil filled the box?

- A. 24cm^3
 B. 64cm^3
 C. 512cm^3
 D. 548cm^3
34. The distance between Khai's home and health centre is 2km 10m. What is the distance in metres only?
- A. 2100m
 B. 2010m
 C. 20100m
 D. 200010
35. The table below shows distance between some areas within Nairobi. The distances were measured from the city centre.

| Place | Distance |
|-------------|-----------|
| Westlands | 3km 760m |
| Kasarani | 16km 500m |
| Imara Daima | 11km 400 |

Amina travelled from Imara Daima to city centre then to Westlands. What distance did she cover?

- A. 11km 400m
 B. 31km 660m
 C. 15km 160m
 D. 3km 760m

36. Work out: $t + 7 = 21$
- A. 3
B. 28
C. 14
D. 147
37. Mwau had 3 baskets with equal number of fruits. The total number of fruits in the baskets was 150. How many fruits are in each basket?
- A. 45
B. 120
C. 50
D. 450
38. Silas is a leader of youth groups. He bought x motorcycles. He shared the motorcycles equally among 7 groups. Each group received 10 motorcycles. Form an equation to represent this information.
- A. $x \div 7 = 10$
B. $7x = 10$
C. $10 \div x = 7$
D. $7 \div x = 10$

39. Mwenje made square tiles whose sides were 28cm by 28cm. What is the total area of 10 such tiles?
- A. 56cm^2
B. 560cm^2
C. 784cm^2
D. 7840cm^2
40. Jacob had a rectangular cardboard. He removed a square piece from it to make a pattern.

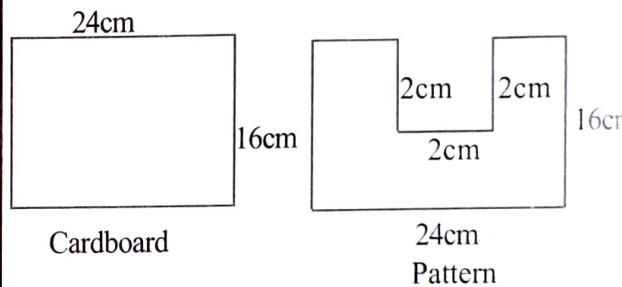

Which one of the following statements is true?

- A. Their perimeters are equal
B. Perimeter of the cardboard is less than the perimeter of the pattern
C. The perimeter of the pattern is less than that of the cardboard.
D. The perimeter of the cardboard is greater than that of the pattern

**THE NYANZA & WESTERN REGIONS KPSEA JOINT
NATIONAL MOCK 2023**



MATHEMATICS

Time: 1 Hour 40 Minutes



READ THESE INSTRUCTIONS CAREFULLY.

1. You have been given this question booklet and a separate answer sheet. The question bookier contains 30 questions.
2. Do any necessary rough work in this booklet.
3. When you have chosen your answer, mark it on the **ANSWER SHET**, not in the question paper.

HOW TO USE THE ANSWER SHEET.

4. Use an ordinary pencil only.
5. Make sure that you have written on the answer sheet.

YOUR INDEX NUMBER

YOUR NAME

NAME OF YOUR SCHOOL

6. By drawing a **dark line** inside the correct numbered boxes mark your full index number (i.e. school code Number and the three -figure candidate's Number) in the grid near the top of the answer sheet.
7. Do not make any marks outside the boxes.
8. Keep your answer sheet as clean as possible and Do not fold it."
9. For each question 1-30 four answers are given. The answers are lettered A, B, C, D. In each case Only One of the four answers is correct. Chose the correct answer.
10. On the answer sheet show the correct answer by drawing a dark line inside the box in which the letter you have chosen is written.
11. Your dark line Must be within the box. Make your line as dark as possible.
12. For each question **Only One box** is to be marked in each set of four boxes.

Candidates should check the question papers to ensure that all questions are printed.

KENYA EDUCATORS CONSULTANCY

1. Which of the following is four hundred and forty thousand four hundred and four in symbols.

- A. 440440 B. 404404
C. 404400 D. 440404

2. What is the total value of digit 9 in 7928314?

- A. Nineteen thousand
B. Nine thousand
C. Nine hundred thousand
D. Ninety thousand

3. What is the value of $25k + 30n + 10k$

- A. $25k + 40n$ B. $15k + 30n$
C. $55K + 10n$ D. $35k + 30n$

4. Convert $\frac{7}{20}$ into percentage

- A. 7% B. 20%
C. 35% D. 70%

5. Divide:

$$6 \overline{) \text{Sh. } 599 \text{ } 40 \text{ cts}}$$

- A. Sh. 93 80 cts
B. Sh. 80 90cts
C. Sh. 90 99cts
D. Sh. 99 90 cts

6. What is 980931 rounded off to the nearest thousand?

- A. 981000
B. 980930
C. 980900
D. 980000

7. Tom was sent to the shop by her mother to buy the following items.

- $1\frac{1}{2}$ kg of rice @ sh. 50 per kg
- 3 bars of soap @ sh. 85
- 3 boxes of matchsticks for sh. 36
- 4 packets of unga @ sh. 80
- $2\frac{1}{4}$ kg of salt @ sh. 20 per kg

If he gave the shopkeeper 2- five hundred shillings notes, what balance was he given?

- A. 1000 B. 741
C. 259 D. 187

8. Find the LCM of 24, 30 and 48?

- A. 180 B. 120
C. 240 D. 480

9. Find the length of this figure if its perimeter is 120m.

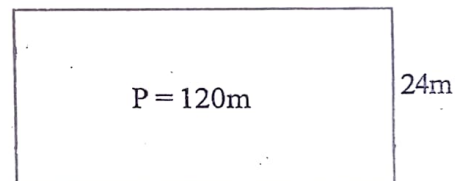

- A. 96m B. 24m
C. 48m D. 36m

10. What is the place value of digit 3 in the number 53418?

- A. Thousands
B. Hundreds
C. Ten thousands
D. Tens

11. Find the area of the figure below.

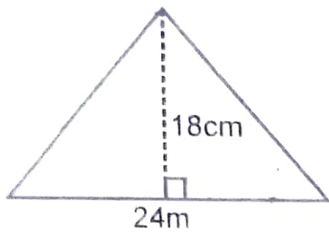

- A. 144cm^2 B. 324cm^2
 C. 216cm^2 D. 432cm^2

12. Add:

$$249852 + 610297 + 353068 =$$

- A. 1312127 B. 1213127
 C. 1213217 D. 131317

13. The fraction $\frac{3}{4}$, $\frac{2}{3}$, $\frac{4}{9}$ and $\frac{5}{6}$ are to be arranged in order from the smallest to the largest. Which of the following is the correct order.

- A. $\frac{2}{3}, \frac{3}{4}, \frac{4}{9}, \frac{5}{6}$ B. $\frac{4}{9}, \frac{2}{3}, \frac{3}{4}, \frac{5}{6}$
 C. $\frac{4}{9}, \frac{2}{3}, \frac{5}{6}, \frac{3}{4}$ D. $\frac{5}{6}, \frac{3}{4}, \frac{2}{3}, \frac{4}{9}$

14. Convert $7\frac{1}{10}$ kg into grammes

- A. 701g B. 71000g
 C. 710g D. 7100g

15. Calculate the area of the shaded part.

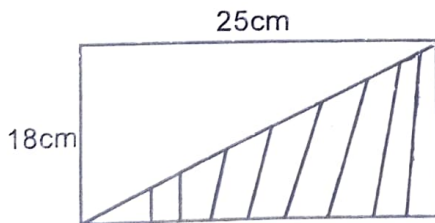

- A. 86cm^2 B. 225cm^2
 C. 450cm^2 D. 235cm^2

16. Write 6 in Roman number.

- A. IX B. XI
 C. IIX D. VI

17. $92 + \sqrt{49}$

- A. 57 B. 88
 C. 56 D. 94

18. Change $6\frac{5}{7}$ to improper fraction

- A. $\frac{96}{7}$ B. $\frac{88}{7}$
 C. $\frac{42}{7}$ D. $\frac{47}{7}$

19. Find the area of the square below.

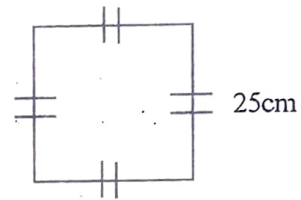

- A. 625m^2 B. 100m^2
 C. 320m^2 D. 2500m^2

20. Which of the following figure is a cuboid?

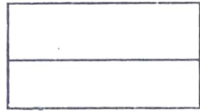
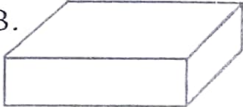
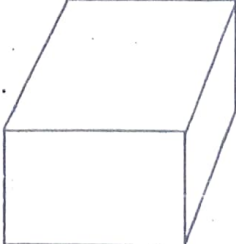
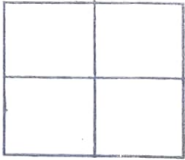
- A.  B. 
- C.  D. 

21. There are 124 wards in a referral hospital. Each ward has 14 beds. How many beds are there altogether?

- A. 1763 B. 1736
C. 138 D. 9

22. In an election for governorship, a candidate got 236105 votes in a certain county. What is the total value of the number in the tens of thousands place value.

- A. 100 B. 6000
C. 2000000 D. 30000

23. The area of a square plot of land is 1296m². What is the length of each side of the plot?

- A. 36m B. 63m
C. 33m D. 45m

24. What is the value of $64 \times 68 \div 17 - 28 + 16 =$

- A. 420 B. 244
C. 202 D. 240

25. What is $\frac{12}{25}$ written as a percentage.

- A. 52% B. 48%
C. 58% D. 40%

6. The angle below is drawn to scale

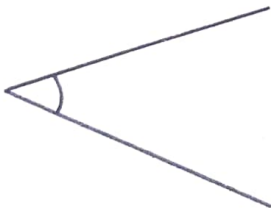

What is the measure of the angle?

- A. 50° B. 40°
C. 45° D. 135°

27. Which of the following are parallel?

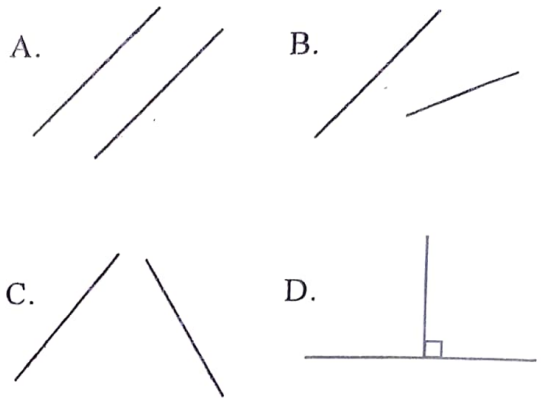

28. Tom had 5 shed with y sheep each. In total he had 20 sheep. Which of the following equations represents this information?

- A. $20xy = 5$
B. $y + 20 = 5$
C. $20 = 5 - y$
D. $5xy = 20$

29. There are c cows in a school. 6 of them were sold and 10 remained. How many cows were there before?

- A. 106 B. 60
C. 4 D. 16

30. Which of the following is a 3- D object?

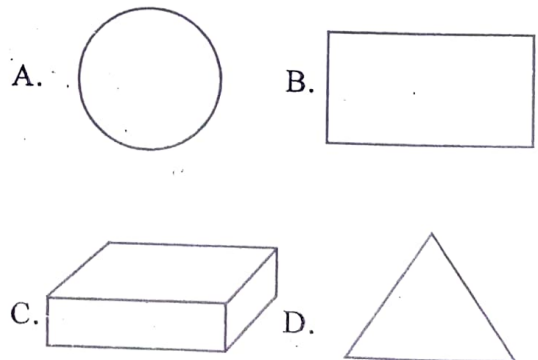

**THE COASTAL & EASTERN REGIONS KPSEA JOINT
NATIONAL MOCK 2023**



MATHEMATICS

Time: 1 Hour 40 Minutes



READ THESE INSTRUCTIONS CAREFULLY.

1. You have been given this question booklet and a separate answer sheet. The question bookier contains 30 questions.
2. Do any necessary rough work in this booklet.
3. When you have chosen your answer, mark it on the **ANSWER SHET**, not in the question paper.

HOW TO USE THE ANSWER SHEET.

4. Use an ordinary pencil only.
5. Make sure that you have written on the answer sheet.

YOUR INDEX NUMBER

YOUR NAME

NAME OF YOUR SCHOOL

6. By drawing a **dark line** inside the correct numbered boxes mark your full index number (i.e. school code Number and the three -figure candidate's Number) in the grid near the top of the answer sheet.
7. Do not make any marks outside the boxes.
8. Keep your answer sheet as clean as possible and Do not fold it."
9. For each question 1-30 four answers are given. The answers are lettered A, B, C, D. In each case Only One of the four answers is correct. Chose the correct answer.
10. On the answer sheet show the correct answer by drawing a dark line inside the box in which the letter you have chosen is written.
11. Your dark line Must be within the box. Make your line as dark as possible.
12. For each question **Only One box** is to be marked in each set of four boxes.

Candidates should check the question papers to ensure that all questions are printed.

KENYA EDUCATORS CONSULTANCY



Working Space

1. There were sixty five thousand and fifty people who attended an agricultural show. What is the number of people in symbols?
 - A. 60550
 - B. 65550
 - C. 60505
 - D. 65050
2. At the beginning of the year, there were 1204 learners in a school. By the end of the year, 132 learners left the school. At the beginning of the following year, 214 joined the school. How many learners are there in the school now?
 - A. 1550
 - B. 1286
 - C. 1122
 - D. 858

3. A teacher displayed the following number cards to the learners.

24362

52628

- A learner rounded off each number in the cards to the nearest hundreds. What was the sum of the rounded numbers?
- A. 76990
 - B. 77000
 - C. 77010
 - D. 77100
4. A factory produced 7435 pieces of soap. The workers packed 1263 pieces of the soap. How many pieces of soap were not packed?
 - A. 6172
 - B. 6232
 - C. 6272
 - D. 8698



Working Space

5. A lorry carried 452 cartons of books. Each carton had 24 books. How many books did the lorry carry altogether?

- A. 11848
- B. 10848
- C. 9648
- D. 2712

6. Work out

$$64 \div 4 \times 2 + 8$$

- A. 160
- B. 40
- C. 16
- D. 4

7. Musa divided his piece of land as shown.

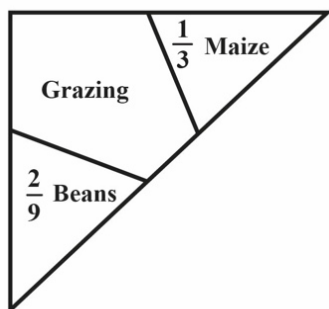

Maize covered $\frac{1}{3}$ of the piece of land while beans covered $\frac{2}{9}$ of the piece of land. What fraction of the land was left for grazing?

- A. $\frac{2}{3}$
- B. $\frac{4}{9}$
- C. $\frac{5}{9}$
- D. $\frac{7}{9}$



Working Space

8. Arrange the fractions $\frac{2}{3}$, $\frac{3}{4}$, $\frac{1}{2}$ from the smallest to the largest. Which one of the following is the correct arrangement?

A. $\frac{1}{2}$, $\frac{3}{4}$, $\frac{2}{3}$

B. $\frac{2}{3}$, $\frac{1}{2}$, $\frac{3}{4}$

C. $\frac{3}{4}$, $\frac{1}{2}$, $\frac{2}{3}$

D. $\frac{1}{2}$, $\frac{2}{3}$, $\frac{3}{4}$

9. A trader arranged her green grocery for sale as shown.

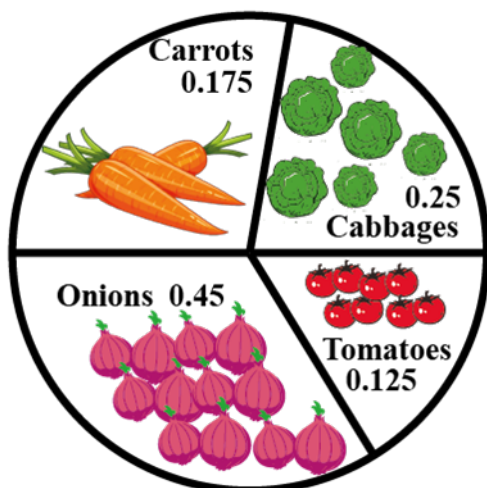

What portion was covered by cabbages, tomatoes and onions?

- A. 0.825
B. 0.700
C. 0.575
D. 0.175
10. Arrange the following decimals 0.75, 1.25, 0.8, 1.135 from the largest to the smallest. Which one of the following is the correct arrangement?

A. 0.75, 0.8, 1.135, 1.25

B. 0.75, 1.135, 1.25, 0.8

C. 1.135, 1.25, 0.8, 0.75

D. 1.25, 1.135, 0.8, 0.75



11. The track shown measures 21 m 45 cm.



- Neema ran on the track three times. What distance did she cover?
- A. 7 m 15 cm
B. 42 m 90 cm
C. 64 m 35 cm
D. 128 m 70 cm
12. A block of wood is 3 metres long. What is the length of the block of wood in centimetres?
- A. 30
B. 300
C. 3000
D. 30000
13. Find the perimeter of the shape shown.

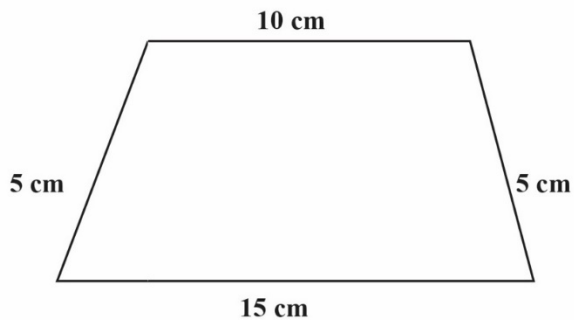

- A. 20 cm
B. 25 cm
C. 30 cm
D. 35 cm

Working Space



Working Space

14. The figure shows a rectangle divided into unit squares.

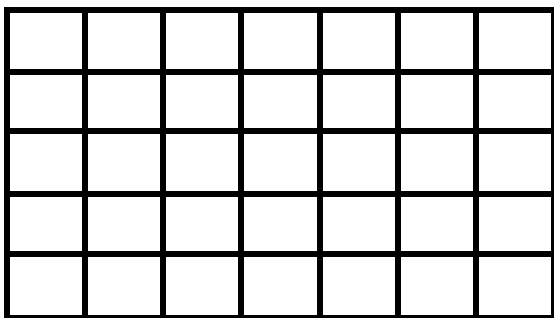

- What is the area of the rectangle?
- A. 35
B. 20
C. 12
D. 5
15. Patel had a sh 1000 note. He changed the money into different denominations. Which one of the following represents the correct change?
- A. sh 500 + sh 200 + sh 100 + sh 50 + sh 50
B. sh 200 + sh 200 + sh 200 + sh 200 + sh 100 + sh 50
C. sh 500 + sh 200 + sh 100 + sh 100 + sh 50
D. sh 500 + sh 200 + sh 200 + sh 100
16. A construction worker bought 175 kg of cement, 473 kg of sand and 282 kg of ballast. What is the total mass of the materials bought?
- A. 930 kg
B. 755 kg
C. 648 kg
D. 457 kg
17. What is the next missing number in the pattern?
- 10, 12, 16, 24, 40, _____
- A. 32
B. 42
C. 64
D. 72



18. The beam balance shown was used to measure the mass of *unga*.

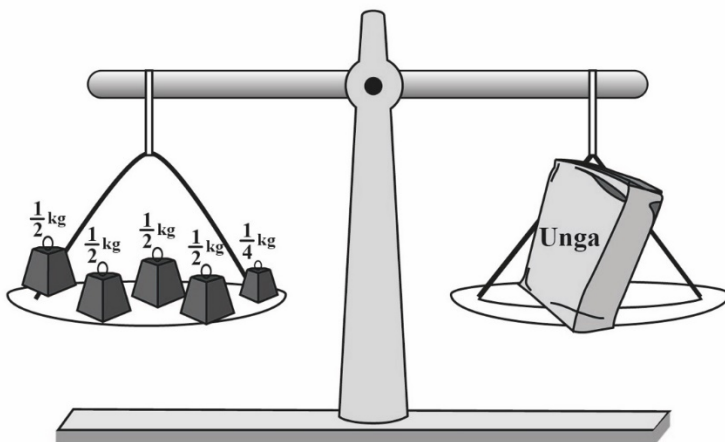

Working Space

What is the mass of *unga* in kilograms?

- A. 5
B. $2\frac{1}{4}$
C. 2
D. $1\frac{1}{4}$
19. A trader bought 260 kg of sugar. He then sold 175 kg of the sugar. Later, the trader bought 195 kg to add to the remainder. How many kilograms of sugar does the trader have now?
- A. 20
B. 85
C. 280
D. 455
20. The figure shows a number on a place value chart.

| | | | | | | |
|----------------------|---|---|---------------|---|---|---|
| Number | 4 | 8 | . | 0 | 5 | 3 |
| Place Value Position | | | Decimal Place | | | |

What is the place value of digit **5** in the number?

- A. Tenths
B. Hundredths
C. Ones
D. Thousandths



21. At a construction site, building blocks were arranged to form the stack as shown.

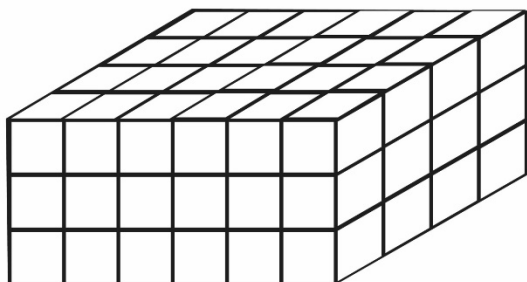

- How many blocks are in the stack?
- A. 18
B. 24
C. 54
D. 72
22. Jeru visited the grandmother for 13 days. How many weeks and days did Jeru take?
- A. 1 week 3 days
B. 1 week 6 days
C. 2 weeks 0 days
D. 2 weeks 3 days
23. Asha started reading a story book in the morning as shown on the digital clock.



She read the storybook for $1\frac{1}{2}$ hours. What time did Asha stop reading the storybook?

- A. 11.45 a.m
B. 11.45 p.m
C. 12.45 a.m
D. 12.45 p.m

Working Space



24. The two clock faces shows the starting time and finishing time of a football match.

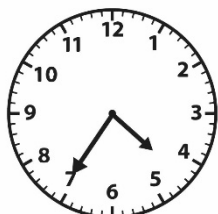

Starting Time

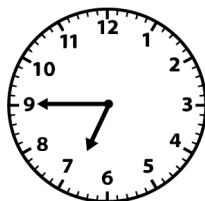

Finishing Time

- How long did the football match take?
- A. 70 minutes
 - B. 120 minutes
 - C. 130 minutes
 - D. 190 minutes
25. Which one of the following lists shows money paid by the public to a county government of Kenya?
- A. Land fees, school fees, parking fee, cess
 - B. Market fees, cess, business permit, security fee
 - C. Market fees, business permit, cess, parking fee
 - D. Land fees, security fee, business permit, parking fee
26. To get to school, Musa walks straight and then turns to the left. What kind of turn does Musa make?
- A. $\frac{1}{4}$ turn
 - B. $\frac{1}{2}$ turn
 - C. $\frac{3}{4}$ turn
 - D. Full turn

Working Space



27. The following is the price list for Furaha shop.

| ITEM | PRICE |
|------------------------|-------|
| A packet of milk | sh 55 |
| A loaf of bread | sh 50 |
| A packet of tea leaves | sh 45 |

Masudi bought 2 packets of milk, a loaf of bread and a packet of tea leaves. He gave the shopkeeper a sh 500 note. What was his balance?

- A. sh 350
B. sh 295
C. sh 255
D. sh 205
28. Ann has some bananas. Tom has the same number of bananas as Ann. Tesse has 3 bananas. Represent the number of bananas Ann has as x . Form an expression to show the number of bananas they have altogether.

- A. $x + x + 3$
B. $x + 3$
C. $3x + 3$
D. $3x$

29. The following are properties of some shapes.

- (i) *All angles are equal.*
(ii) *Has 4 lines of symmetry.*
(iii) *All sides are equal.*

Which shape is represented by the above properties?

- A. A right angled triangle
B. An equilateral triangle
C. A square
D. A rectangle

Working Space



30. The table represents the number of new COVID-19 cases in various counties on a certain day. The cases for Nairobi county is not shown.

| County | Frequency |
|---------|-----------|
| Nairobi | - |
| Nakuru | 135 |
| Garissa | 17 |
| Kwale | 8 |
| Kisii | 10 |

The total number of COVID-19 cases on that day was 656. What was the number of cases in Nairobi county on that day?

- A. 170
- B. 386
- C. 486
- D. 1142

Working Space

**THE RIFT VALLEY & NORTH EASTERN REGIONS KPSEA
JOINT NATIONAL MOCK 2023**

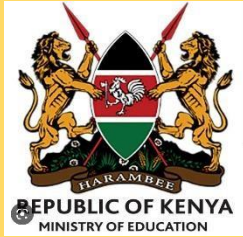

MATHEMATICS

Time: 1 Hour 40 Minutes



READ THESE INSTRUCTIONS CAREFULLY.

1. You have been given this question booklet and a separate answer sheet. The question bookier contains 30 questions.
2. Do any necessary rough work in this booklet.
3. When you have chosen your answer, mark it on the **ANSWER SHET**, not in the question paper.

HOW TO USE THE ANSWER SHEET.

4. Use an ordinary pencil only.
5. Make sure that you have written on the answer sheet.

YOUR INDEX NUMBER

YOUR NAME

NAME OF YOUR SCHOOL

6. By drawing a **dark line** inside the correct numbered boxes mark your full index number (i.e. school code Number and the three -figure candidate's Number) in the grid near the top of the answer sheet.
7. Do not make any marks outside the boxes.
8. Keep your answer sheet as clean as possible and Do not fold it."
9. For each question 1-30 four answers are given. The answers are lettered A, B, C, D. In each case Only One of the four answers is correct. Chose the correct answer.
10. On the answer sheet show the correct answer by drawing a dark line inside the box in which the letter you have chosen is written.
11. Your dark line Must be within the box. Make your line as dark as possible.
12. For each question **Only One box** is to be marked in each set of four boxes.

Candidates should check the question papers to ensure that all questions are printed.

KENYA EDUCATORS CONSULTANCY

1. In a certain county, there were 2139408 registered voters. During a group activity in a Mathematics lesson, learners discussed the position of each digit and recorded in the chart below.

| | | | | | | | |
|-------------|----------|-----------------------|-------------------|-----------|----------|------|------|
| Place value | Millions | Hundreds of thousands | Tens of thousands | Thousands | Hundreds | Tens | Ones |
| Digit | | | | X | | | |

Which digit did they write in the place marked X?

- A. 9
 B. 4
 C. 3
 D. 1
2. The government distributed a total of 4090578 textbooks to learners in the country. What is the total number of books written in words?
- A. Four million ninety thousand five hundred and seventy eight
 B. Forty million ninety thousand five hundred and seventy eight
 C. Four million nine thousand five hundred and seventy eight
 D. Four million ninety five thousand and seventy eight
3. Soi bought 94825 tree seedlings. He planted 68904 tree seedlings in the first week and the rest in the second week. How many tree seedlings did he plant in the second week?
- A. 167729
 B. 26921
 C. 35921
 D. 25921

4. Some grade 5 learners were playing a number game using number cards. The cards were labelled with digits 8, 0, 2, 5, 4 and 3. They arranged the cards to form the smallest number. What is the value of digit 3 in the number formed?

- A. Thousands
 B. Three thousand
 C. Thirty thousand
 D. Three hundred

5. A matatu conductor is paid sh 450 everyday. How much was he paid from 4th January to 4th March 2020?

- A. Sh 27900
 B. Sh 27450
 C. Sh 27000
 D. Sh 26550

6. The number of people who were tested for Covid-19 in four sub-counties were as shown in the table below.

| Sub-county | Umoja | Uwezo | Fadhili | Amani |
|---------------|-------|-------|---------|-------|
| No. of people | 1728 | 2202 | 1571 | 1692 |

Which one of the following is the correct way of writing the number of people from the smallest to the largest?

- A. 2202, 1728, 1692, 1571
 B. 1571, 1628, 2202, 1728
 C. 1571, 1692, 1728, 2202
 D. 1728, 2202, 1571, 1692

7. Lucy and Alice were skipping on the number line from 0

Lucy

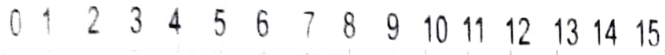

Alice

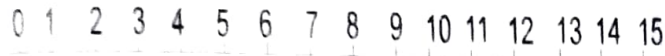

Lucy skipped 4 steps while Alice skipped 3 steps. At what point on the number line will they skip again from the same point?

- A. 0
B. 1
C. 7
D. 12
8. In a certain month, the electricity bill of a school was sh 3581. The secretary rounded off the bill to the nearest thousands and paid off. How much money did the secretary pay?
- A. Sh 4000
B. Sh 3500
C. Sh 3580
D. Sh 3000
9. Four fruit vendors bought fruits as follows: Nyawira 2044, Nafula 2056, Anyango 1800 and Yiamit 1792. They each sold their fruits in groups of five. Who did not have any remaining fruits?
- A. Nafula
B. Anyango
C. Yiamit
D. Nyawira

10. A trader had two bags of rice 30 kg and 20 kg. She put the rice into smaller bags of equal mass. What is the greatest mass of each of the smaller bags she obtained by sub-dividing the rice equally without a remainder?

- A. 5
B. 60
C. 10
D. 600
11. What is the missing number in the pattern below? 20, 24, 32, 48, 80, _____
- A. 64
B. 128
C. 84
D. 144

12. Work out: $24 \div 8 \times 5 + 12 - 17$

- A. 27
B. 10
C. 15
D. 5
13. Laban had wires of lengths $\frac{1}{2}$ m, $\frac{3}{4}$ m, $\frac{5}{8}$ m and $\frac{1}{6}$ m. He arranged the wires from the shortest to the longest. Which one of the following is the correct order?

- A. $\frac{1}{6}, \frac{1}{2}, \frac{5}{8}, \frac{3}{4}$
B. $\frac{3}{4}, \frac{5}{8}, \frac{1}{2}, \frac{1}{6}$
C. $\frac{1}{2}, \frac{1}{6}, \frac{3}{4}, \frac{5}{8}$
D. $\frac{1}{6}, \frac{1}{2}, \frac{3}{4}, \frac{5}{8}$

14. After selling meat in the morning, a butcher had $\frac{2}{3}$ of meat remaining by noon. In the afternoon he sold $\frac{4}{9}$ of the meat and sold the rest in the evening. What fraction of the meat did he sell in the evening?

- A. $\frac{2}{9}$
- B. $\frac{1}{9}$
- C. $\frac{2}{6}$
- D. $\frac{6}{12}$

15. During a Mathematics activity, a group formed a number that had 3 ones, 6 tenths, 7 hundredths and 4 thousandths. Which one of the following numbers did they form?

- A. 0.3674
- B. 3.674
- C. 30.674
- D. 36.074

16. In the school athletics competition, four athletes completed the 5000 metre race as follows: Kirui 16.97, Wanjiru 16.92, Moraa 16.99 and Chebet 16.95. What is the correct order of arranging the athletes from the fastest to the slowest?

- A. Moraa, Chebet, Wanjiru, Kirui
- B. Kirui, Moraa, Chebet, Wanjiru
- C. Wanjiru, Chebet, Kirui, Moraa
- D. Moraa, Kirui, Chebet, Wanjiru

17. The circle below shows how Nkirote divided her land.

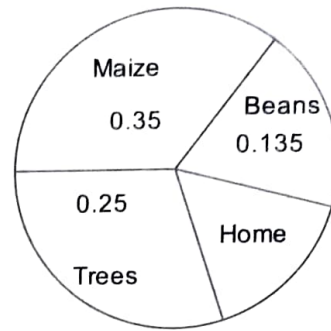

What portion of the land was covered by maize, beans and trees?

- A. 0.735
- B. 0.725
- C. 0.635
- D. 0.265

18. The distance from Mutua's home to county headquarters is 46km 200m. He cycled for 38km 450m and got a puncture. What distance was he left with to reach the county headquarters?

- A. 84km 650m
- B. 7km 750m
- C. 8km 750m
- D. 8km 250m

19. The length of a road is 7km. A contractor tarmacked the whole road. What length in metres of the road was tarmacked?

- A. 70
- B. 7000
- C. 700
- D. 70000

20. Below are table mats which were made by two people.

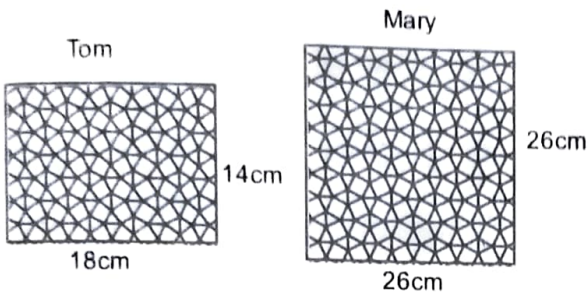

What is the difference in the areas of the table mats they made?

- A. 252cm^2
 - B. 424cm^2
 - C. 676cm^2
 - D. 928cm^2
21. The diagram below shows a school compound.

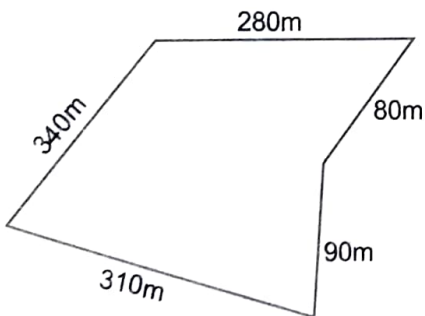

The head teacher walked round the school compound to check if it was fenced properly.

How many metres did she cover?

- A. 1100
- B. 1010
- C. 1000
- D. 900

22. Owang' dug a hole to plant a tree seedling. The hole was 8cm long, 9cm wide and 12cm deep. What volume of soil did he remove from the hole?

- A. 29cm^3
- B. 72cm^3
- C. 108cm^3
- D. 864cm^3

23. Sulciman used small cubes to make a big cube like the one shown below.

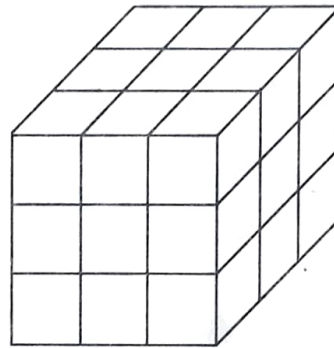

How many small cubes did he use?

- A. 9
 - B. 18
 - C. 24
 - D. 27
24. A trader had 72kg of sugar. She repacked the sugar into quarter kilogram packets. How many packets did she get?
- A. 18
 - B. 24
 - C. 144
 - D. 288

25. Amin imported 8452kg of fertilizer. He sold 6370kg of the fertilizer to farmers. How many kilograms of fertilizer remained?
- A. 14822
B. 2092
C. 2082
D. 1982

26. Muthoni used a beam balance to measure the mass of salt as shown below.

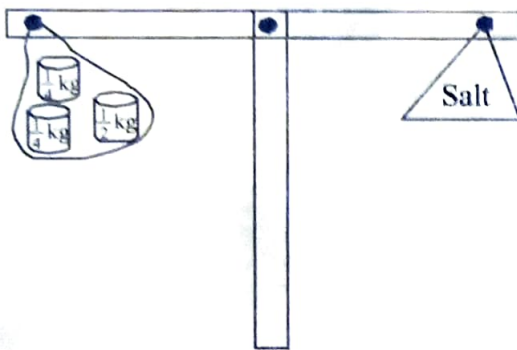

What is the mass of salt in kilograms?

- A. 1kg
B. $1\frac{1}{2}$ kg
C. $2\frac{1}{2}$ kg
D. 3kg
27. A construction company bought 350kg of cement, 946kg of sand and 564kg of ballast. What is the total mass of the materials the company bought?
- A. 1860
B. 1510
C. 1296
D. 914
28. Mwachia's cow produced 25000ml of milk everyday. How many litres does the cow produce each day?
- A. 2500
B. 250
C. 25
D. $2\frac{1}{2}$
29. A petrol station had 362419 litres of petrol. A total of 98320 litres of the petrol was sold in one hour. How much petrol remained?
- A. 274099
B. 264099
C. 274199
D. 264199
30. Miriam divided 19 minutes 30 seconds by 6. What answer did she get?
- A. 3 minutes 5 seconds
B. 3 minutes 50 seconds
C. 3 minutes 15 seconds
D. 3 minutes 20 seconds
31. Auma took 46 minutes 30 seconds to wash 9 blankets. She took equal amount of time to wash one blanket. How long did she take to wash one blanket?
- A. 5 minutes 10 seconds
B. 6 minutes 10 seconds
C. 5 minutes 15 seconds
D. 5 minutes 14 seconds

32. Which one of the following is an importance of budget?

- A. Enables us to buy everything
- B. Helps us to work hard to spend
- C. Helps us to spend all the money
- D. Helps us to spend wisely and save

33. Godia earns a salary every month. He spends part of it and saves sh 1200 every month. How much does he save in 2 years?

- A. Sh 28800
- B. Sh 14400
- C. Sh 36000
- D. Sh 33600

34. Omwayo took 6 hours 28 minutes to drive to the town. Lwanya took 5 hours 25 minutes. How much more time did Omwayo took to drive to town than Lwanya?

- A. 2 hours 3 minutes
- B. 1 hour 3 minutes
- C. 1 hour 30 minutes
- D. 10 hours 53 minutes

35. Below is a price list in Amani's shop

| Item | Price |
|--------------------------|--------|
| One packet of flour | Sh 140 |
| Loaf of bread | Sh 55 |
| 1 kg of cooking fat | Sh 238 |
| 1 kg of sugar | Sh 135 |
| $\frac{1}{2}$ kg of salt | Sh 56 |

Mareb bought one packet of flour, two loaves of bread, a packet of salt. She paid for the items using sh 500 note. How much balance did she get?

- A. Sh 306
- B. Sh 249
- C. Sh 222
- D. Sh 194

36. Below is a clock face

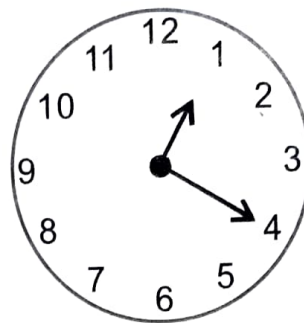

Which one of the following angles have been formed by the hour and minute hands of the clock?

- A. Reflex
- B. Obtuse
- C. Acute
- D. Right angled

37. During a Mathematics lesson, a teacher asked four learners to draw perpendicular lines. They drew as follows:

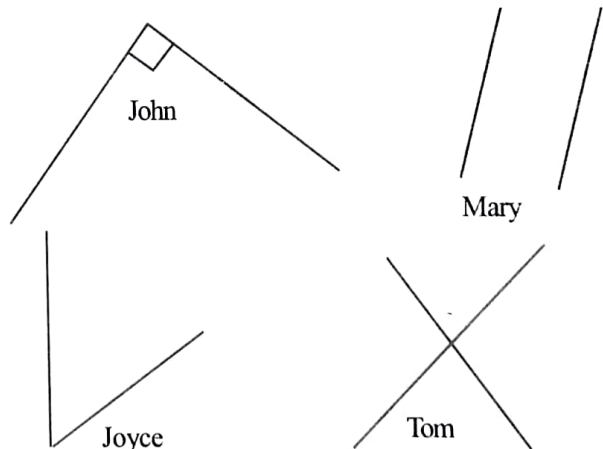

Who was correct?

- A. John
- B. Mary
- C. Joyce
- D. Tom

38. Mwaniki is your group member. He is unable to use a protractor to measure the angle drawn below. Measure the angle and show him how to measure the angle.

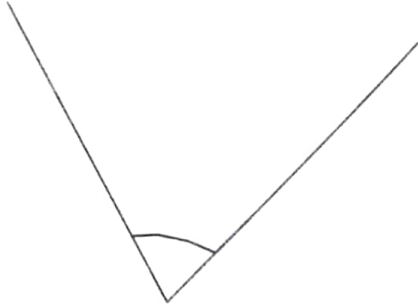

What is the measure of the angle?

- A. 75°
- B. 105°
- C. 85°
- D. 115°

39. Mutembei had x books. A quarter of the books is 12. How many books does Mutembei have?

- A. 2
- B. 3
- C. 36
- D. 48

40. In a class, some learners chose their favourite subjects as follows.

| Subject | Tally marks | No. of learners |
|------------------------|-------------|-----------------|
| Maths | | 12 |
| English | | 8 |
| Kiswahili | | 4 |
| Science and Technology | | 16 |

Which one of the following is the correct way of representing the number of learners using tally marks?

| | A | B | C | D |
|------------------------|-------------|-------------|--------------|-------------|
| Maths | ### ### // | ### ## // | ## ### // | // ## ## |
| English | ##### | ### /// | ### /// | //// # |
| Kiswahili | ## | //// | ## | //// |
| Science and Technology | ##### ##### | ### ## ## / | ## ### ///// | ### ## //// |